

SharePoint

Ntlangeni Andile Leon ▾ ?



KZN HEALTH

KZN Health Intranet

Search this site

[HOME](#) [CORPORATE INFORMATION](#) [COMPONENTS](#) [DIRECTORY](#) [DISTRICT OFFICES](#) [HEALTH FACILITIES](#)

KZN Health > Components > Supply Chain Management

AdvertQuote



Quotation Advert

Opening Date: 2021-08-30

Closing Date: 2021-09-10

Closing Time: 11:00

INSTITUTION DETAILS

Institution Name: Madadeni hospital

Province: KwaZulu-Natal

Department or Entity: Department of Health

Division or section: Central Supply Chain Management

Place where goods / services is required: Madadeni Hospital

Date Submitted: 2021-08-30

ITEM CATEGORY AND DETAILS

Quotation Number: ZNQ: MAD/546/22

Item Category: Services

Item Description: Supply and erect Flu clinic as per the drawing and specification at Madadeni clinic 1
Requirements: CIDB: GB, SO and EB

Quantity (if supplies): As per Specification

COMPULSORY BRIEFING SESSION / SITE VISIT

Select Type: Compulsory Briefing Session

Date: 2021-09-01

Time: 11:30

Venue: Madadeni clinic 1

QUOTES CAN BE COLLECTED FROM: Quotes have been uploaded together with the advert. Service providers are requested to come with their documents.

QUOTES SHOULD BE DELIVERED TO: Quotes must be sent to Madadeni.SCM@kznhealth.gov.za or hand deliver at Madadeni hospital, in the Admin tender box.

ENQUIRIES REGARDING THE ADVERT MAY BE DIRECTED TO:

Name: Mr. AL Ntlangeni

Email:

Contact Number: 034 328 8269

Finance Manager Name:

Mr. MP Msomi

Finance Manager Signature:

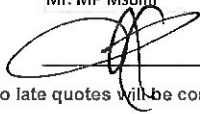
No late quotes will be considered

DECLARATION OF INTEREST

1. Any legal person, including persons employed by the state¹, or persons having a kinship with persons employed by the state, including a blood relationship, may make an offer or offers in terms of this invitation to quote (includes a price quotation, advertised competitive quote, limited quote or proposal). In view of possible allegations of favouritism, should the resulting quote, or part thereof, be awarded to persons employed by the state, or to persons connected with or related to them, it is required that the bidder or his/her authorised representative declare his/her position in relation to the evaluating/adjudicating authority where-
- the bidder is employed by the state; and/or
 - the legal person on whose behalf the bidding document is signed, has a relationship with persons/a person who are/is involved in the evaluation and or adjudication of the quote(s), or where it is known that such a relationship exists between the person or persons for or on whose behalf the declarant acts and persons who are involved with the evaluation and or adjudication of the quote.
2. In order to give effect to the above, the following questionnaire must be completed and submitted with the quote.

- 2.1. Full Name of bidder/representative..... 2.4. Company Registration Number:
- 2.2. Identity Number: 2.5. Tax Reference Number:
- 2.3. Position occupied in the Company (director, trustee, shareholder²):..... 2.6. VAT Registration Number:

2.7. The names of all directors / trustees / shareholders / members, their individual identity numbers, tax reference numbers and, if applicable, employee / persal numbers must be indicated in paragraph 3 below. [TICK APPLICABLE]

2.8. Are you or any person connected with the bidder presently employed by the state? YES NO

2.8.1. If so, furnish the following particulars:
 Name of person / director / trustee / shareholder/ member:
 Name of state institution at which you or the person connected to the bidder is employed:.....
 Position occupied in the state institution:Any other particulars:.....

2.8.2. If you are presently employed by the state, did you obtain the appropriate authority to undertake remunerative work outside employment in the public sector? YES NO

2.8.2.1. If yes, did you attach proof of such authority to the quote document?

(Note: Failure to submit proof of such authority, where applicable, may result in the disqualification of the quote.)

2.8.2.2. If no, furnish reasons for non-submission of such proof:

2.9. Did you or your spouse, or any of the company's directors / trustees / shareholders / members or their spouses conduct business with the state in the previous twelve months? YES NO

2.9.1. If so, furnish particulars:.....

2.10. Do you, or any person connected with the bidder, have any relationship (family, friend, other) with a person employed by the state and who may be involved with the evaluation and or adjudication of this quote? YES NO

2.10.1. If so, furnish particulars:.....

2.11. Are you, or any person connected with the bidder, aware of any relationship (family, friend, other) between any other bidder and any person employed by the state who may be involved with the evaluation and or adjudication of this quote? YES NO

2.11.1. If so, furnish particulars:.....

2.12. Do you or any of the directors / trustees / shareholders / members of the company have any interest in any other related companies whether or not they are bidding for this contract? YES NO

2.12.1. If so, furnish particulars:.....

3. Full details of directors / trustees / members / shareholders.

NB: The Department Of Health will validate **details of directors / trustees / members / shareholders** on CSD. It is the suppliers' responsibility to ensure that their details are up-to-date and verified on CSD. If the Department cannot validate the **information** on CSD, the quote will not be considered and passed over as non-compliant according to National Treasury Instruction Note 4 (a) 2016/17.

4. DECLARATION

I, THE UNDERSIGNED (NAME).....CERTIFY THAT THE INFORMATION FURNISHED IN PARAGRAPHS 2.

I ACCEPT THAT THE STATE MAY REJECT THE QUOTE OR ACT AGAINST ME SHOULD THIS DECLARATION PROVE TO BE FALSE.

.....
Name of bidder	Signature	Position	Date

¹"State" means –

- | | |
|---|---|
| a) any national or provincial department, national or provincial public entity or constitutional institution within the meaning of the Public Finance Management Act, 1999 (Act No. 1 of 1999); | c) provincial legislature; |
| b) any municipality or municipal entity; | d) national Assembly or the national Council of provinces; or |
| | e) Parliament. |

²"Shareholder" means a person who owns shares in the company and is actively involved in the management of the enterprise or business and exercises control over the enterprise.

SPECIAL CONTRACT CONDITIONS OF QUOTATIONS

1. AMENDMENT OF CONTRACT

- 1.1. Any amendment to or renunciation of the provisions of the contract shall at all times be done in writing and shall be signed by both parties.

2. CHANGE OF ADDRESS

- 2.1. Bidders must advise the Department of Health (institution where the offer was submitted) should their address (*domicillium citandi et executandi*) details change from the time of bidding to the expiry of the contract.

3. GENERAL CONDITIONS ATTACHED TO THIS QUOTATION

- 3.1. The institution is under no obligation to accept the lowest or any quote.
- 3.2. The price quoted must include VAT (if VAT vendor). However, it must be noted that the department reserves the right to evaluate all quotations excluding VAT as some bidders may not be VAT vendors.
- 3.3. The bidder must ensure the correctness & validity of quote:
(i) *that the price(s), rate(s) & preference quoted cover all for the work/item (s) & accept that any mistakes regarding the price (s) & calculations will be at the bidder's risk*
- 3.4. The bidder must accept full responsibility for the proper execution & fulfilment of all obligations conditions devolving on under this agreement, as the Principal (s) liable for the due fulfilment of this contract.
- 3.5. This quotation will be evaluated based on the 80/20 points system, specification & correctness of information. All required documentation must be completed in full and submitted.
- 3.6. Offers must comply strictly with the specification.
- 3.7. Only offers that meet or are greater than the specification will be considered.
- 3.8. Late quotes will not be considered.
- 3.9. Expired product/s will not be accepted. All products supplied must be valid for a minimum period of six months.
- 3.10. A bidder not registered on the Central Suppliers Database or verification has failed will not be considered.
- 3.11. All delivery costs must be included in the quote price, for delivery at the prescribed destination.
- 3.12. Only firm prices will be accepted. Such prices must remain firm for the contract period. Non-firm prices (including rates of exchange variations) will not be considered.
- 3.13. In cases where different delivery points influence the pricing, a separate pricing schedule must be submitted for each delivery point.
- 3.14. In the event of a bidder having multiple quotes, only the cheapest according to specification will be considered. Furthermore a verification will be done to identify if bidders have multiple companies and are quoting (cover-quoting) for this bid. In such instances only the cheapest bid according to specification will be considered.

4. SPECIAL INSTRUCTIONS AND NOTICES TO BIDDERS REGARDING THE COMPLETION OF THIS QUOTATION.

- 4.1. Unless inconsistent with or expressly indicated otherwise by the context, the singular shall include the plural and vice versa and with words importing the masculine gender shall include the feminine and the neuter.
- 4.2. Under no circumstances whatsoever may the quotation/bid forms be retyped or redrafted. Photocopies of the original bid documentation may be used, but an original signature must appear on such photocopies.
- 4.3. The bidder is advised to check the number of pages and to satisfy himself that none are missing or duplicated.
- 4.4. Quotation submitted must be complete in all respects.
- 4.5. Any alteration made by the bidder must be initialled.
- 4.6. Use of correcting fluid is prohibited
- 4.7. Quotation will be opened in public as soon as practicable after the closing time of quotation.
- 4.8. Where practical, prices are made public at the time of opening quotations.
- 4.9. If it is desired to make more than one offer against any individual item, such offers should be given on a photocopy of the page in question. Clear indication thereof must be stated on the schedules attached.

5. SPECIAL INSTRUCTIONS REGARDING HAND DELIVERED QUOTATIONS

- 5.1. Quotation shall be lodged at the address indicated not later than the closing time specified for their receipt, and in accordance with the directives in the quotation documents.
- 5.2. Each quotation shall be addressed in accordance with the directives in the quotation documents and shall be lodged in a separate sealed envelope, with the name and address of the bidder, the quotation number and closing date indicated on the envelope. The envelope shall not contain documents relating to any quotation other than that shown on the envelope. If this provision is not complied with, such quotations/bids may be rejected as being invalid.
- 5.3. All quotations received in sealed envelopes with the relevant quotation numbers on the envelopes are kept unopened in safe custody until the closing time of the quotation/bids. Where, however, a quotation is received open, it shall be sealed. If it is received without a quotation/bid number on the envelope, it shall be opened, the quotation number ascertained, the envelope sealed and the quotation number written on the envelope.
- 5.4. A specific box is provided for the receipt of quotations, and no quotation found in any other box or elsewhere subsequent to the closing date and time of quotation will be considered.

- 5.5. No quotation/bid sent through the post will be considered if it is received after the closing date and time stipulated in the quotation documentation, and proof of posting will not be accepted as proof of delivery.
- 5.6. Quotation documents must not be included in packages containing samples. Such quotations may be rejected as being invalid.

6. SAMPLES

- 6.1. In the case of the quote document stipulating that samples are required, the supplier will be informed in due course when samples should be provided to the institution. (This decreases the time of safety and storage risk that may be incurred by the respective institution). The bidders sample will be retained if such bidder wins the contract.
 - (i) If a company/s who has not won the quote requires their samples, they must advise the institution in writing of such.
 - (ii) If samples are not collected within three months of close of quote the institution reserves the right to dispose of them at their discretion.
- 6.2. **Samples must be made available when requested in writing or if stipulated on the document.**
 - (i) If a Bidder fails to provide a sample of their product on offer for scrutiny against the set specification when requested, their offer will be rejected. All testing will be for the account of the bidder.

7. COMPULSORY SITE INSPECTION / BRIEFING SESSION

7.1. Bidders who fail to attend the compulsory meeting will be disqualified from the evaluation process.

- (i) The institution has determined that a compulsory site meeting take place
- (ii) Date / / Time : Place

Institution Stamp:	Institution Site Inspection / briefing session Official Full Name: Signature: Date:
--------------------	--

8. STATEMENT OF SUPPLIES AND SERVICES

8.1. The contractor shall, when requested to do so, furnish particulars of supplies delivered or services executed. If he/she fails to do so, the Department may, without prejudice to any other rights which it may have, institute inquiries at the expense of the contractor to obtain the required particulars.

9. SUBMISSION AND COMPLETION OF SBD 6.1

9.1. Should a bidder wish to qualify for preference points they must complete a SBD 6.1 document. Failure by a bidder to provide all relevant information required, will result in such a bidder not being considered for preference point's allocation. The preferences applicable on the closing date will be utilized. Any changes after the closing date will not be considered for that particular quote.

10. TAX COMPLIANCE REQUIREMENTS

- 10.1. In the event that the tax compliance status has failed on CSD, **it is the suppliers' responsibility to provide a SARS pin in order for the institution to validate the tax compliance status of the supplier.**
- 10.2. In the event that the institution cannot validate the suppliers' tax clearance on SARS as well as the Central Suppliers Database, **the quote will not be considered and passed over as non-compliant according to National Treasury Instruction Note 4 (a) 2016/17.**

11. TAX INVOICE

11.1. A tax invoice shall be in the currency of the Republic of South Africa and shall contain the following particulars:

- (i) the name, address and registration number of the supplier;
- (ii) the name and address of the recipient;
- (iii) an individual serialized number and the date upon which the tax invoice is issued;
- (iv) a description and quantity or volume of the goods or services supplied;
- (v) the official department order number issued to the supplier;
- (vi) the value of the supply, the amount of tax charged;
- (vii) the words tax invoice in a prominent place.

12. PATENT RIGHTS

The supplier shall indemnify the **KZN Department of Health** (hereafter known as the purchaser) against all third-party claims of infringement of patent, trademark, or industrial design rights arising from use of the goods or any part thereof by the purchaser.

13. PENALTIES

- 13.1. If at any time during the contract period, the service provider is unable to perform in a timely manner, the service provider must notify the institution in writing/email of the cause of and the duration of the delay. Upon receipt of the notification, the institution should evaluate the circumstances and, if deemed necessary, the institution may extend the service provider's time for performance.
- 13.2. In the event of delayed performance that extends beyond the delivery period, the institution is entitled to purchase commodities of a similar quantity and quality as a substitution for the outstanding commodities, without terminating the contract, as well as return commodities delivered at a later stage at the service provider's expense.
- 13.3. Alternatively, the institution may elect to terminate the contract and procure the necessary commodities in order to complete the contract. In the event that the contract is terminated the institution may claim damages from the service provider in the form of a penalty. The service provider's performance should be captured on the service provider database in order to determine whether or not the service provider should be awarded any contracts in the future.
- 13.4. If the supplier fails to deliver any or all of the goods or to perform the services within the period(s) specified in the contract, the purchaser shall, without prejudice to its other remedies under the contract, deduct from the contract price, as a penalty, a sum calculated on the delivered price of the delayed goods or unperformed services using the current prime interest rate calculated for each day of the delay until actual delivery or performance.

14. TERMINATION FOR DEFAULT

- 14.1. The purchaser, without prejudice to any other remedy for breach of contract, by written notice of default sent to the supplier, may terminate this contract in whole or in part:
 - (i) if the supplier fails to deliver any or all of the goods within the period(s) specified in the contract,
 - (ii) if the supplier fails to perform any other obligation(s) under the contract; or
 - (iii) if the supplier, in the judgment of the purchaser, has engaged in corrupt or fraudulent practices in competing for or in executing the contract.
- 14.2. In the event the purchaser terminates the contract in whole or in part, the purchaser may procure, upon such terms and in such manner as it deems appropriate, goods, works or services similar to those undelivered, and the supplier shall be liable to the purchaser for any excess costs for such similar goods, works or services.
- 14.3. Where the purchaser terminates the contract in whole or in part, the purchaser may decide to impose a restriction penalty on the supplier by prohibiting such supplier from doing business with the public sector for a period not exceeding 10 years.

15. FAILURE TO COMPLY WITH ABOVE WILL RESULT IN YOUR QUOTE BEING PASSED OVER.

PREFERENCE POINTS CLAIM FORM IN TERMS OF THE PREFERENTIAL PROCUREMENT REGULATIONS 2017

This preference form must form part of all quotes invited. It contains general information and serves as a claim form for preference points for Broad-Based Black Economic Empowerment (B-BBEE) Status Level of Contribution

NB: BEFORE COMPLETING THIS FORM, BIDDERS MUST STUDY THE GENERAL CONDITIONS, DEFINITIONS AND DIRECTIVES APPLICABLE IN RESPECT OF B-BBEE, AS PRESCRIBED IN THE PREFERENTIAL PROCUREMENT REGULATIONS, 2017.

1. GENERAL CONDITIONS

1.1 The following preference point systems are applicable to all quotes:

- the 80/20 system for requirements with a Rand value of up to R50 000 000 (all applicable taxes included); and

1.2 The value of this quote is estimated to not exceed R50 000 000 (all applicable taxes included) and therefore the 80/20 preference point system shall be applicable.

1.3 Points for this quote shall be awarded for:

- (a) Price; and
- (b) B-BBEE Status Level of Contributor.

1.4 The maximum points for this quote is allocated as follows:

	POINTS
PRICE	80
B-BBEE STATUS LEVEL OF CONTRIBUTOR	20
Total points for Price and B-BBEE must not exceed	100

1.5 Failure on the part of a bidder to submit proof of B-BBEE Status level of contributor together with the quote, will be interpreted to mean that preference points for B-BBEE status level of contribution are not claimed.

1.6 The purchaser reserves the right to require of a bidder, either before a quote is adjudicated or at any time subsequently, to substantiate any claim in regard to preferences, in any manner required by the purchaser.

2. DEFINITIONS

- (a) **"B-BBEE"** means broad-based black economic empowerment as defined in section 1 of the Broad-Based Black Economic Empowerment Act;
- (b) **"B-BBEE status level of contributor"** means the B-BBEE status of an entity in terms of a code of good practice on black economic empowerment, issued in terms of section 9(1) of the Broad-Based Black Economic Empowerment Act;
- (c) **"bid"** means a written offer in a prescribed or stipulated form in response to an invitation by an organ of state for the provision of goods or services, through price quotations, advertised competitive bidding processes or proposals;
- (d) **"Broad-Based Black Economic Empowerment Act"** means the Broad-Based Black Economic Empowerment Act, 2003 (Act No. 53 of 2003);
- (e) **"EME"** means an Exempted Micro Enterprise in terms of a code of good practice on black economic empowerment issued in terms of section 9 (1) of the Broad-Based Black Economic Empowerment Act;
- (f) **"functionality"** means the ability of a tenderer to provide goods or services in accordance with specifications as set out in the tender documents.
- (g) **"prices"** includes all applicable taxes less all unconditional discounts;
- (h) **"proof of B-BBEE status level of contributor"** means:
 - 1) B-BBEE Status level certificate issued by an authorized body or person;
 - 2) A sworn affidavit as prescribed by the B-BBEE Codes of Good Practice;
 - 3) Any other requirement prescribed in terms of the B-BBEE Act;
- (i) **"QSE"** means a qualifying small business enterprise in terms of a code of good practice on black economic empowerment issued in terms of section 9 (1) of the Broad-Based Black Economic Empowerment Act;
- (j) **"rand value"** means the total estimated value of a contract in Rand, calculated at the time of bid invitation, and includes all applicable taxes;

3. POINTS AWARDED FOR PRICE

3.1 THE 80/20 PREFERENCE POINT SYSTEMS

A maximum of 80 points is allocated for price on the following basis:

$$Ps = 80 \left(1 - \frac{Pt - P \min}{P \min} \right) \text{ Where}$$

- Ps = Points scored for price of bid under consideration
- Pt = Price of bid under consideration
- Pmin = Price of lowest acceptable bid

4. POINTS AWARDED FOR B-BBEE STATUS LEVEL OF CONTRIBUTOR

4.1 In terms of Regulation 6 (2) and 7 (2) of the Preferential Procurement Regulations, preference points must be awarded to a bidder for attaining the B-BBEE status level of contribution in accordance with the table below:

B-BBEE Status Level of Contributor	Number of points (80/20 system)
1	20
2	18
3	14
4	12
5	8
6	6
7	4
8	2
Non-compliant contributor	0

5. BID DECLARATION

5.1 Bidders who claim points in respect of B-BBEE Status Level of Contribution must complete the following:

6. B-BBEE STATUS LEVEL OF CONTRIBUTOR CLAIMED IN TERMS OF PARAGRAPHS 1.4 AND 4.1

6.1 B-BBEE Status Level of Contributor: =(maximum of 20 points)

(Points claimed in respect of paragraph 7.1 must be in accordance with the table reflected in paragraph 4.1 and must be substantiated by relevant proof of B-BBEE status level of contributor.

7. SUB-CONTRACTING

(Tick applicable box)

7.1 Will any portion of the contract be sub-contracted?

YES	<input type="checkbox"/>	NO	<input type="checkbox"/>
-----	--------------------------	----	--------------------------

7.1.1 If yes, indicate:

- i) What percentage of the contract will be subcontracted.....%
- ii) The name of the sub-contractor.....
- iii) The B-BBEE status level of the sub-contractor.....

8. Whether the sub-contractor is an EME or QSE

(Tick applicable box)

iv) Specify, by ticking the appropriate box, if subcontracting with an enterprise in terms of Preferential Procurement Regulations,2017:

YES	<input type="checkbox"/>	NO	<input type="checkbox"/>
-----	--------------------------	----	--------------------------

Designated Group: An EME or QSE which is at last 51% owned by:	EME √	QSE √
Black people		
Black people who are youth		
Black people who are women		
Black people with disabilities		
Black people living in rural or underdeveloped areas or townships		
Cooperative owned by black people		
Black people who are military veterans		
OR		
Any EME		
Any QSE		

9. **DECLARATION WITH REGARD TO COMPANY/FIRM**

9.1 Name of company/firm:.....

9.2 VAT registration number:.....

9.3 Company registration number:.....

9.4 TYPE OF COMPANY/ FIRM [TICK APPLICABLE BOX]

- Partnership/Joint Venture / Consortium
- One person business/sole propriety
- Close corporation
- Company
- (Pty) Limited

9.5 DESCRIBE PRINCIPAL BUSINESS ACTIVITIES

.....

.....

9.6 COMPANY CLASSIFICATION [TICK APPLICABLE BOX]

- Manufacturer
- Supplier
- Professional service provider
- Other service providers, e.g. transporter, etc.

9.7 Total number of years the company/firm has been in business:.....

9.8 I/we, the undersigned, who is / are duly authorised to do so on behalf of the company/firm, certify that the points claimed, based on the B-BBE status level of contributor indicated in paragraphs 1.4 and 6.1 of the foregoing certificate, qualifies the company/ firm for the preference(s) shown and I / we acknowledge that:

- i) The information furnished is true and correct;
- ii) The preference points claimed are in accordance with the General Conditions as indicated in paragraph 1 of this form;
- iii) In the event of a contract being awarded as a result of points claimed as shown in paragraphs 1.4 and 6.1, the contractor may be required to furnish documentary proof to the satisfaction of the purchaser that the claims are correct;
- iv) If the B-BBEE status level of contributor has been claimed or obtained on a fraudulent basis or any of the conditions of contract have not been fulfilled, the purchaser may, in addition to any other remedy it may have –
 - (a) disqualify the person from the bidding process;
 - (b) recover costs, losses or damages it has incurred or suffered as a result of that person's conduct;
 - (c) cancel the contract and claim any damages which it has suffered as a result of having to make less favourable arrangements due to such cancellation;
 - (d) recommend that the bidder or contractor, its shareholders and directors, or only the shareholders and directors who acted on a fraudulent basis, be restricted by the National Treasury from obtaining business from any organ of state for a period not exceeding 10 years, after the *audi alteram partem* (hear the other side) rule has been applied; and
 - (e) forward the matter for criminal prosecution.

WITNESSES
1.
2.

..... SIGNATURE(S) OF BIDDERS(S)
DATE:
ADDRESS.....

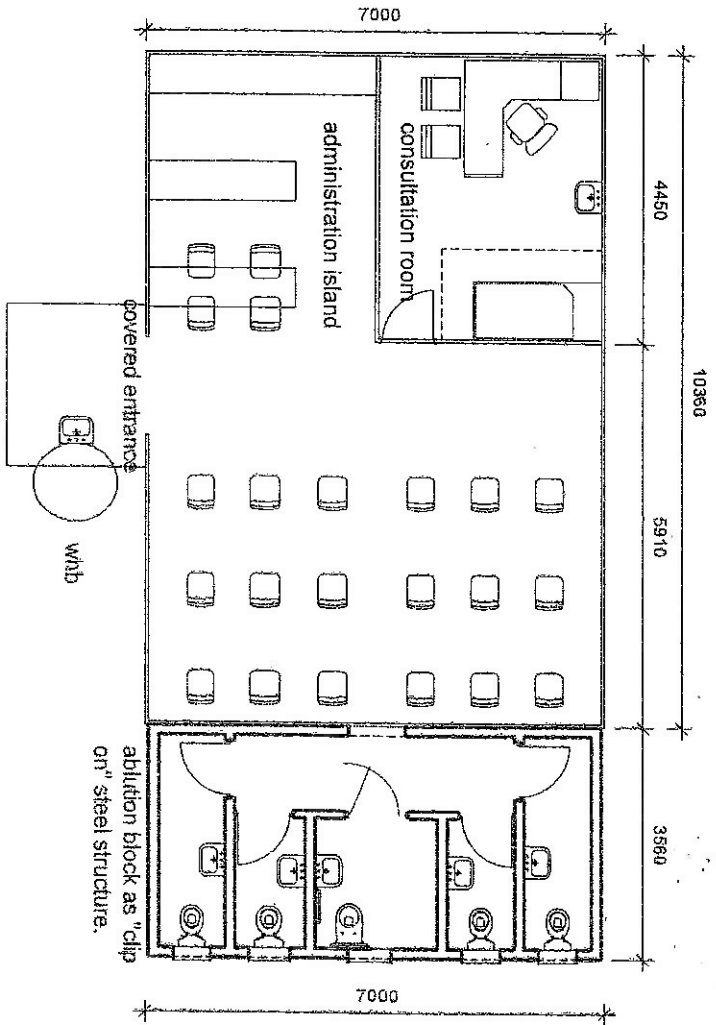

m staff
 f/m staff
 paraplegic
 m patients
 f/m patients

**TENTED FLU CLINIC - scale
 1:100**

 <p>health Department: Health PROVINCE OF KWAZULU-NATAL</p>	PROJECT DESCRIPTION	WORKSTAGE	
	TENTED FLU CLINIC PROPOSAL	Line diagram	
			Date: 4/6/20
			Scale: 1 : 100
			Rev.



Supply and erect Flu clinic
Madadeni Clinic 1
MADADENI HOSPITAL
ZNO NO: _____

Closing Date & Time : @ 11h00

Contract Period : 6 Weeks

Validity Period : 60 Days

Technical Contact Person : MR. SV Mbatha

Contact Telephone Number : 034 328 8201

On Site Inspection :

WORK DISCIPLINE:

CIDB (E.B.,S.O.,G.B)

This is a multi-disciplinary Contract and Contractors should only tender for services in respect of their own areas of expertise. The Tenderer shall in the Schedule of Information, and by way of supplementary information, satisfy the Head of Department or his or her designee that sufficient equipment is possessed to execute the services, or an indication shall be given as to the manner in which such equipment would be sourced. Should the Tenderer not be able to prove possession of, or ability to access, sufficient equipment, the Tender will be wholly disqualified. The Head of Department or his or her designee reserves the right to investigate the existence and/or proposed sourcing of equipment.

The Tenderer also will be required to satisfy the Head of Department or his or her designee that a sufficient/qualified and experienced labour force is employed, or that sufficient experienced labour can be acquired, to complete the services and produce a fair quality of workmanship. The Tenderer will be required to produce adequate and sufficient references to enable the Head of Department or his or her designee to inspect previously completed work and assess the capacity of the Tenderer.

The Head of Department or his or her designee reserves the right to recommend that Tenderers execute work of only certain types and up to certain capacities due to the limitations of experience and skills of the Tenderer. Any limitations to such work tendered for will be recommended to the Central Procurement Committee for approval and will be applied strictly during the contract period.

The successful Tenderer shall supply all materials, labour, tools and plant etc., necessary to carry out maintenance, repairs, servicing, upgrading, replacement, and minor new works to buildings.

**Supply and erect Flu clinic
Madadeni Clinic I
MADADENI HOSPITAL**

ZNO NO:

PROJECT SPECIFICATIONS

7.	NOTES TO TENDERS	
1.1.	SCOPE OF CONTRACT	This Contract is for the complete execution of the project indicated above.
1.2.	CONDITIONS OF CONTRACT AND PRELIMINARIES	
1.2.1	PERIOD OF CONTRACT	06Week as the Contract Period for the completion of <i>all Works</i> from date of Site handover.
1.2.2	CONTRACT GUARANTEE:	The successful Tenderer will <u>NOT</u> be required to submit a contract guarantee.
1.2.3	GUARANTEE PERIOD	The guarantee period for <i>all Works</i> and all materials must be for a minimum of <i>One (1) Year</i> from the date of first delivery. UNLESS SPECIFIED
1.2.4	SITE AND MODE OF PROCEDURE	The work contained in this contract will be carried out on the site of the existing Institution. The Contractor is advised that the existing premises will be occupied throughout the period of the contract. Damage to existing buildings - Tenderers to note that any damages done or occurring to any of the buildings will be repaired at the expense of the contractor/ Tenderer. The repairs must be to the satisfaction of the KwaZulu-Natal Department of Health.

Safety file must be produced and handed to safety department before commencement

1.2.7 Health and safety act 85(1993)

NB: COC will be required for any electrical work done

1.2.6 CERTIFICATE OF COMPLIANCE

Copies of the KZNPA Standard Preambles to all Trades and the KZNPA General Electrical Specification are available at the office of the Secretary for Health – KwaZulu-Natal and can be obtained on request.

The whole of the installation shall be carried out in accordance with the South African Bureau of Standards Code of Practice for the application of National Building Regulations, the KZNPA Standard Preambles to all Trades, REGULATION R158, the KZNPA General Electrical Specification, the South African Bureau of Standards Code of Practice for the Wiring of Premises 0142-1 and the Occupational Health and Safety Act 85 of 1993 as amended.

1.2.5 SATISFACTORY INSTALLATION

TECHNICAL SPECIFICATIONS

2. TECHNICAL SPECIFICATION

2.1 GENERAL

This TECHNICAL SPECIFICATION shall be read in conjunction with all other sections of the SPECIFICATION and cognisance shall be taken of the clauses relevant to this particular installation, whether any specific clauses are referred to or not.

TECHNICAL SPECIFICATIONS

2. TECHNICAL SPECIFICATION

2.1 GENERAL

This TECHNICAL SPECIFICATION shall be read in conjunction with all other sections of the SPECIFICATION and cognisance shall be taken of the clauses relevant to this particular installation, whether any specific clauses are referred to or not.

2.2 *Standard Preambles*

This is available from the department on request.

2.3 *Health and Safety Specification*

Health and Safety Plan with Risk assessment schedule is to be compiled taking cognisance of the specific type of patient's that walk around the institution all day. All areas are to be protected at all times from patients falling in. All new and old materials are to be securely stored during construction to eliminate any person from rolling them around or playing inside them.

1. Specifications

- 1.1 Floors and foundations
- To be ready mixed and smooth furnish to accept the vinyl sheet. (20mpa strength)
 - To be 1 meter overlap around the building (strip around the building)
- 1.2 Steel structure
- 76 x 76 x 2mm SQ tubing
 - 76 x 38 x 1.6mm Rectangular tubing
 - 76 x 50 x20 x2mm channel
- 1.3 Roof structure
- To be full length 8.2m x 0.52mm thick 18R fixed on the 76 x 50 x20 x2mm channel
 - Fascia and Burge (car port structure to be used and painted white using gloss enamel paint.)
- 1.4 Windows
- To be 1.2 x1.2m (SHH 1212) SIDE HUNG ALUMINIUM-Fixed to the 76 x 38 x 1.6mm Rectangular tubing (USE A FROSTED GLASS)
 - To be 600 x 600mm TOP HUNG ALUMINIUM-Fixed to the 76 x 38 x 1.6mm Rectangular tubing(USE A FROSTED GLASS) IN ABLUTION
- 1.5 Doors
- To aluminium standard (single and double as per the given drawings) WHITE
- 1.6 Walls
- To be fibre cement (10-12mm Nutec MD board- 1200 x 3000/3600mm) internal and external Fixed with counter sunk screws to the 76 x 38 x 1.6mm Rectangular tubing
 - Epoxy filler to be used between the joints (10mm)
 - The fixing structure(the 76 x 38 x 1.6mm Rectangular tubing) to be 600mm horizontally apart, and the counter sunk screws to be 400mm c/c
- 1.7 Ceilings
- To be fibred cement (6mm Nutec MD board- 1200 x 3000/3600mm) internal and external Fixed with counter sunk screws to the 76 x 38 x 1.6mm Rectangular tubing
- 1.8 Ablutions
- Toilets as per given drawings
 - Showers as per given drawings
 - Hand basins as per given drawings

Supply and erect Flu clinic

3. SCOPE OF WORK

The work to be carried out under this contract includes the supply of all materials, and including all labour to carry out all electrical work and leaving in service condition to the satisfaction of the Secretary for Health: Kwazulu-Natal.

3.1. The work comprises of

3.2

- a) Earthworks
- b) Concrete Work
- c) Roof Sheeting
- d) Steel Work
- e) Plumbing
- f) Drainage

Scope of works

- 1.1 Supply and erect Floors and foundations -30m³ 20mpa
- 1.2 Supply and erect the Steel structure
- 1.3 Supply and erect Roof structure
- 1.4 Supply and install the Windows (Clinic and ablutions)
- 1.5 Supply and install the Doors
- 1.6 Supply and install the Walls 460 m²
- 1.7 Ceilings 160m²
- 1.8 Supply and install the ablutions facility as per the given drawings

EARTHWORKS

SITE CLEARANCE:—The item given in the Bills of Quantities for site clearance shall be deemed to include the removal from the site, or burning if permitted by the Local Authority, of shrubs and trees with trunks under 200mm girth measured at 1m above ground level, hedges, bushes, other vegetation, rubbish and debris. Holes left by roots are to be backfilled with earth and rammed.

EXCAVATIONS:— Rates for excavations are to include for forming and trimming to the correct levels, falls, slopes, curves, etc. for trimming sides, stepping, levelling and ramming bottoms, staging and disposing of the excavated material as described in the items. Rates for excavations to reduce levels over site are also to include for forming and trimming banks to the required batter. The Contractor is to allow in his rates for the bulking of excavated material.

PLUMBING
DRAINAGE

0.2mm thick, 100x125mm built-in carports gutters, in continuous lengths including bends, down pipes, stopped ends etc. Fixed to manufactures specifications to the approval of DOH
100 x 125mm gutter closure
PVC Down pipe 2400 long
PVC band
PVC Shoe
PVC Holder bat

STEEL ROOF SHEETING AND ACCESSORIES

Finishing
Roof sheeting and accessories shall galvanized white powder coated roof sheets
0.6mm white powder coated metal roof sheet fixed to 150x50mm lipped channel
Roof sheet

SCHEDULE OF RATES
WORK TO BE DONE AT MADADENI HOSPITAL AND SCHEDULE OF PRICES:

Item	DESCRIPTION	UNIT	QTY	RATE/UNIT			TOTAL	
				R	c	R		
	<p>INSTITUTION:MADADENI HOSPITAL ZNO NO: All rates quoted shall be inclusive of transport, Labour and profit. The Tenderer is advised that the buildings are occupied</p>							
	<p>PROPRIETARY ARTICLES: All equipment and material used in this contract shall be that which is specified or other SABS approved.</p>							
1	<p>Allow for site preparations and decanting. To be ready mixed and smooth furnish to accept the vanyl sheet. (20mpa strength) To be 1 meter overlap around the building</p>	ITEM						
2	<p>Allow for site preparations and decanting. To be ready mixed and smooth furnish to accept the vanyl sheet. (20mpa strength) To be 1 meter overlap around the building</p>	ITEM						
3	<p>Allow for concrete slab including reducing levels, layers works, compaction etc (CONCRETE, FORMWORK AND REINFORCEMENT) To be ready mixed and smooth furnish to accept the vanyl sheet. (20mpa strength) To be 1 meter overlap around the building</p>	M ³	40					
4	<p>STRUCTURAL STEELWORK (Walls) •76 x 76 x 2mm SQ tubing •76 x 38 x 1.6mm Rectangular tubing •76 x 50 x20 x2mm channel</p>	ITEM						
5	<p>Roof structure To be full length 8.2m x 0.5mm (Min)thick IBR to be painted with a roof paint (Color to determined) Gutters and down pipes to meet the DOH standards Fascia and Burge (painted white using gloss enamel paint.)</p>	ITEM						
CARRIED TO COLLECTION SUMMARY								
PS 1								

R

**SCHEDULE OF RATES
WORK TO BE DONE AT MADADENI HOSPITAL AND SCHEDULE OF PRICES:**

Item	DESCRIPTION	UNIT	QTY	RATE/UNIT		TOTAL
				R	c	
	<p>INSTITUTION: MADADENI HOSPITAL ZNO NO: All rates quoted shall be inclusive of transport, Labour and profit. The Tenderer is advised that the buildings are occupied</p>					
	<p>PROPRIETARY ARTICLES: All equipment and material used in this contract shall be that which is specified or other SABS approved.</p>					
1.	<p>Windows – White powder coated To be 1.2 x1.2m (SHH 1212) SIDE HUNG ALUMINIUM-Fixed to the 76 x 38 x 1.6mm Rectangular tubing (USE A MIRROR GLASS) for the clinic To be 600 x 600mm TOP HUNG ALUMINIUM-Fixed to the 76 x 38 x 1.6mm Rectangular tubing(USE A FROSTED GLASS) for ablutions</p>	ITEM				
2.	<p>Doors - White powder coated To aluminium standard (single and double as per the given drawings)</p>					
3.	<p>Walls To be fibred cement (12mm Nutec MD board- 1200 x 3000/3600mm) internal and external Fixed with counter sunk screws to the 76 x 38 x 1.6mm Rectangular tubing Epoxy filler to be used between the joints (10mm) The fixing structure(the 76 x 38 x 1.6mm Rectangular tubing) to be 600mm horizontally apart, and the counter sunk screws to be 400mm c/c</p>	M ²	460			
4.	<p>Ceilings To be fibre cement (6mm Nutec MD board- 1200 x 3000/3600mm Fixed with counter sunk screws to the 76 x 38 x 1.6mm Rectangular tubing</p>					
CARRIED TO COLLECTION SUMMARY						
PS 2						
					R	

SCHEDULE OF RATES WORK TO BE DONE AT MADADENI HOSPITAL AND SCHEDULE OF PRICES:							
Item	DESCRIPTION	UNIT	QTY	RATE/UNIT			TOTAL
				R	c	R	
	INSTTUTION:MADADENI HOSPITAL ZNO NO: All rates quoted shall be inclusive of transport, Labour and profit. The Tenderer is advised that the buildings are occupied.						
	PROPRIETARY ARTICLES: All equipment and material used in this contract shall be that which is specified or other SABS approved.						
5.	Paint in white weather guard 10 years wash and wear paint (Sampling area to be done for approval)	M ²					
5	Allow for 210 litres sanitation desk , mounted on 610 x 610 x 900mm high welded steel desk as per given drawing.	Item					
6	Allow for the desk and the chairs as per the given drawing (Waiting area and consulting rooms)	Item					
6.	Allow for the electrification of the entire building (8 x 5foot double tube), (3 x double socket outlet "Crab tree") The power must be taken from the nearest main clinic DB COC to be issued.	Item					
				R			
				PS 3			
				CARRIED TO COLLECTION SUMMARY			

COLLECTION SUMMARY

PROJECT DESCRIPTION:
Supply and erect Flu clinic

ZNO NO:

NOTE:
THIS COLLECTION SUMMARY MUST BE COMPLETED IN FULL BY THE CONTRACTOR AND RETURNED TOGETHER WITH THE QUOTATION FORM.

	R	Collection Summary PS 1		
	R	Collection Summary PS 2		
	R	Collection Summary PS 3		
	R	Safety requirements		
	R	Sub total		

 Mr. SV Mbatha
 Chief Artisan

Date
 24/08/2021

 Sign Contractor

 Sign Date

MADADENI HOSPITAL
Maintenance
Project Policy

Supply and erect Flu clinic
Madadeni Clinic 1

1. Presentation of an official order from SCM will mean that the service provider must immediately report to the maintenance department.
2. Detailed work plan-it must be presented as per days e.g. day1, Day2, Day3 or Program (Service provider must indicate the delivery period on the quotation).
3. No work will be commenced without submitting a work plan and a safety plan; delay caused by the contractor failing to submit will result to penalties.
4. There will be a compulsory progress meeting every week depending on the project period. (Friday at 11h00) and only the company director or a proxy to attend.
5. Take note of paragraph 13 and 14 on the quote special conditions.
6. Reference page must be completed.

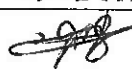
Mr. SV Mbatsha
Chief Artisan

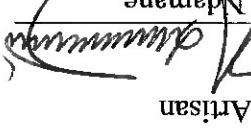
Mr. N Ndumane
Deputy Director Systems

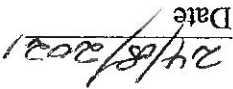
Date 24/08/2021

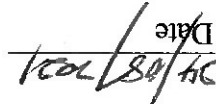
Date 24/08/2021

Mr T Zwane
Assistant Director SCM

Date

Company Director/ Company name

SCHEDULE OF RATES

3.1 ITEMS AND PRICING

The Department reserves the right to place an order for any quantities of items included in the Schedules. The Schedule of Rates must also not be assumed to include and describe every detail of the supply requirement, but must be taken and read in conjunction with the other parts of the document. Thus the supplier shall not have claim for further payment in respect of any order which may be described or implied in the contract, although apparently no corresponding items are given in the Schedule of Rates. The supplier shall be deemed to have satisfied himself before quoting as to the correctness and sufficiency of his quote for the contract and of the rates and prices stated in the Schedule of Rates.

3.2 TAX AND DUTIES

Prices, quoted and paid, must include all customs, excise and import duties, and any other tariffs or taxes levied by the government or statutory body having jurisdiction on the goods provided under this contract, including Value Added Tax (applicable to the current rate).

3.3 RATES

Except where provision is made in the Schedule of Rates, the rates and prices inserted shall be the full rates and prices for the service delivered described under the respective items and shall cover all labour, transport, overhead charges and profit, etc. as well as the general liabilities, obligations and risks arising out of the Conditions of Contract, the overhead charges and profit being spread proportionately over the rates of the relative items in the Schedule of Rates.

15

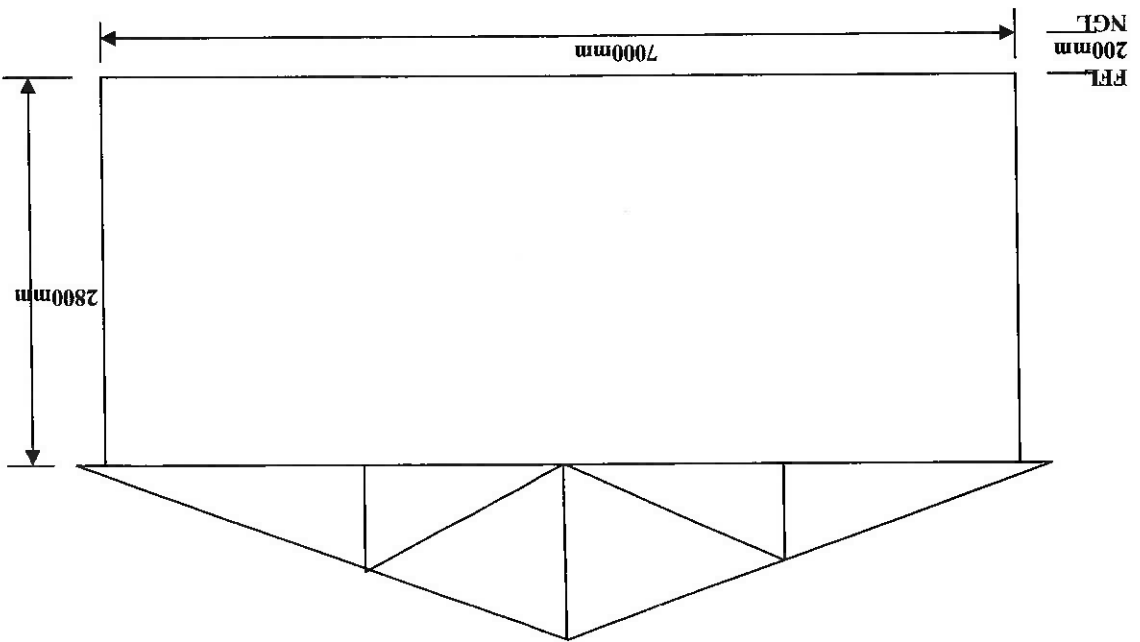
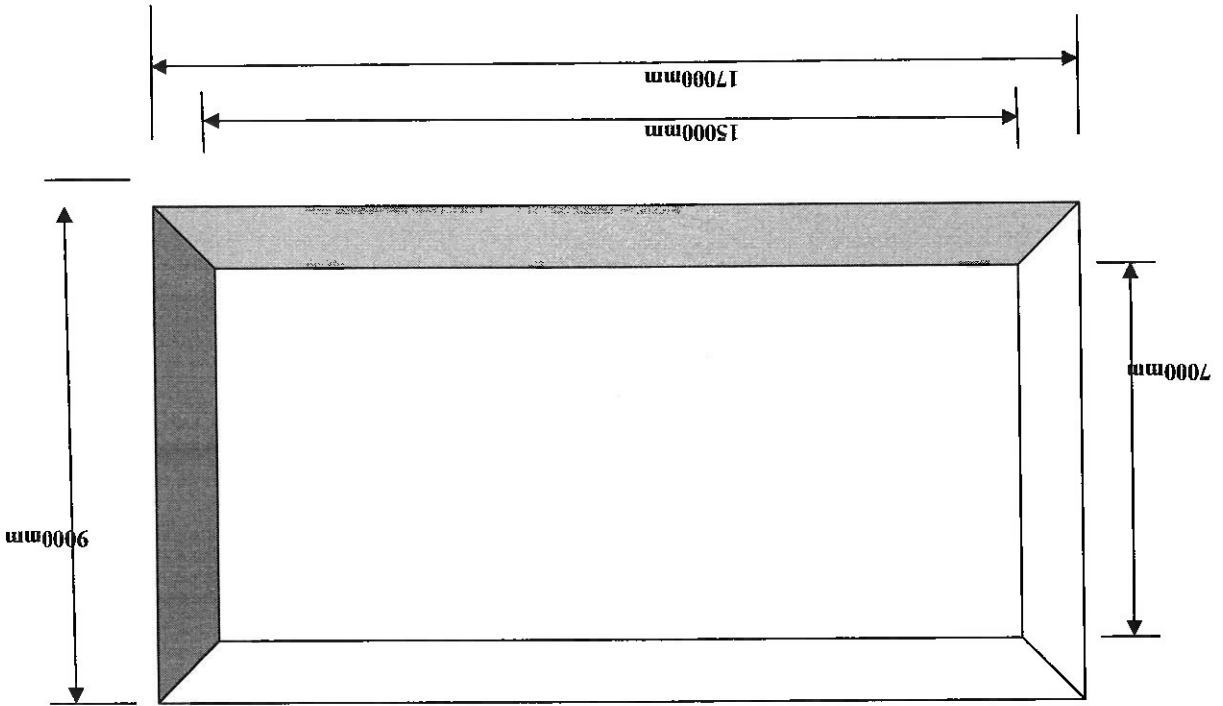

San ware Description:
Code:
¼ turn wall type mixer with a swivel outlet and a hook, ½"
Elbow action
BSP male inlet, SANS 226 TYPE 2
515/055H-21
Description:
Code:
Elbow action pillar type
¾" BSP male inlets, SANS 226 TYPE 2
¼ turn mixer with an aerated swan neck swivel
outlet.
515-21

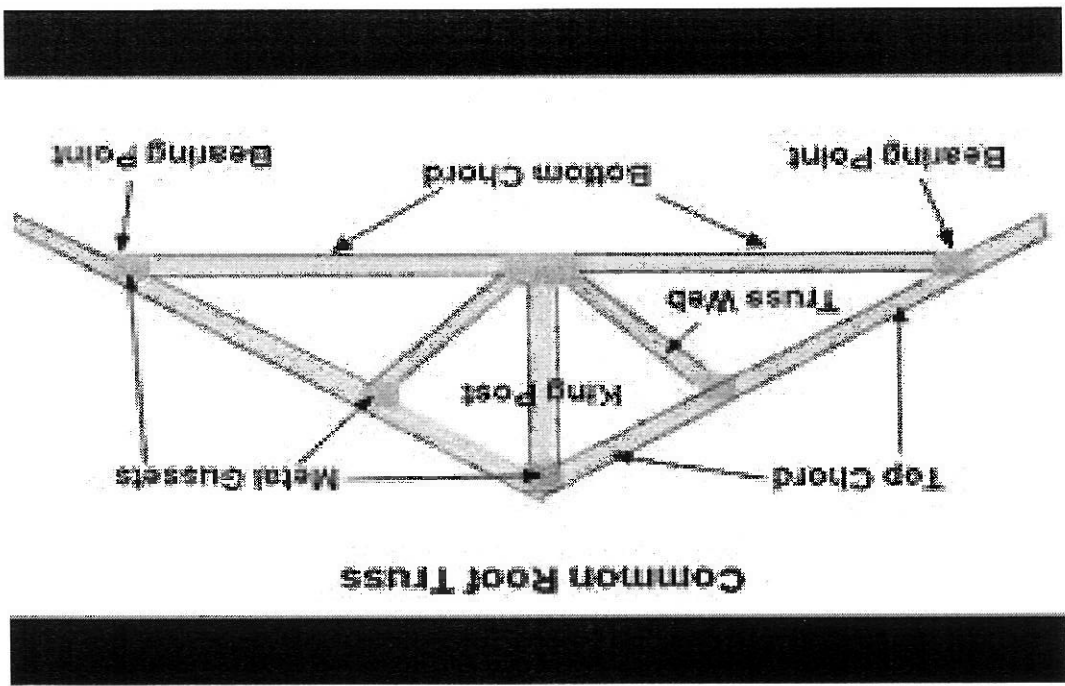

Common Roof Truss

LAUFEN PRO B WALL HUNG BASIN
 COLOUR WHITE (CODE: LAWHOS10952), SIZE 600 X 480mm
 WITH NO TAP HOLES, NO INTEGRATED OVERFLOW AND NO CHAINSTAY HOLE
 INSTALLED IN ACCORDANCE WITH MANUFACTURERS INSTRUCTIONS AND SEALED WITH SILICONE SEALANT WHERE
 BASIN MEETS WALL
 COBRA WATERTECH 515/055H-21 WALL MOUNTED ELBOW ACTION MEDICAL MIXER WITH SWIVEL OUTLET
 MANUFACTURED IN ACCORDANCE WITH SANS 228:2004 TYPE 2, COMPLETE WITH OVERFLOW TUBE AND HOOK
 WATER SUPPLY TO BE HOT AND COLD WATER
 COBRA CHROME PLATED BOTTLE TRAP 340P, TAIL PIPE C-342/1 AND WALL FLANGE C-342/3
 COBRA WASTE 308 UNSLOTTED WITH 62mm FLANGE
 REGULATING VALVES TO BE POSITIONED IN CEILING - TO WET SERVICE ENGINEERS SPECIFICATIONS
 NO MIRRORS
 PAPER TOWEL DISPENSER TYPE 1 - SERRA FLAT FOLDED PAPER TOWEL DISPENSER COMPLETE WITH LOCK & KEY
 GRADE 304 STAINLESS STEEL SATIN FINISH A735 WITH 450 C FOLD TOWEL CAPACITY SUPPLIED WITH SERRA
 DISPOSOR SLIMLINE WALL BIN IN SATIN STAINLESS STEEL FINISH
 SOAP DISPENSER TYPE A - SERRA HI-SCRUB GRADE 304 STAINLESS STEEL SOAP DISPENSER SUPPLIED
 COMPLETE WITH BOTTLE

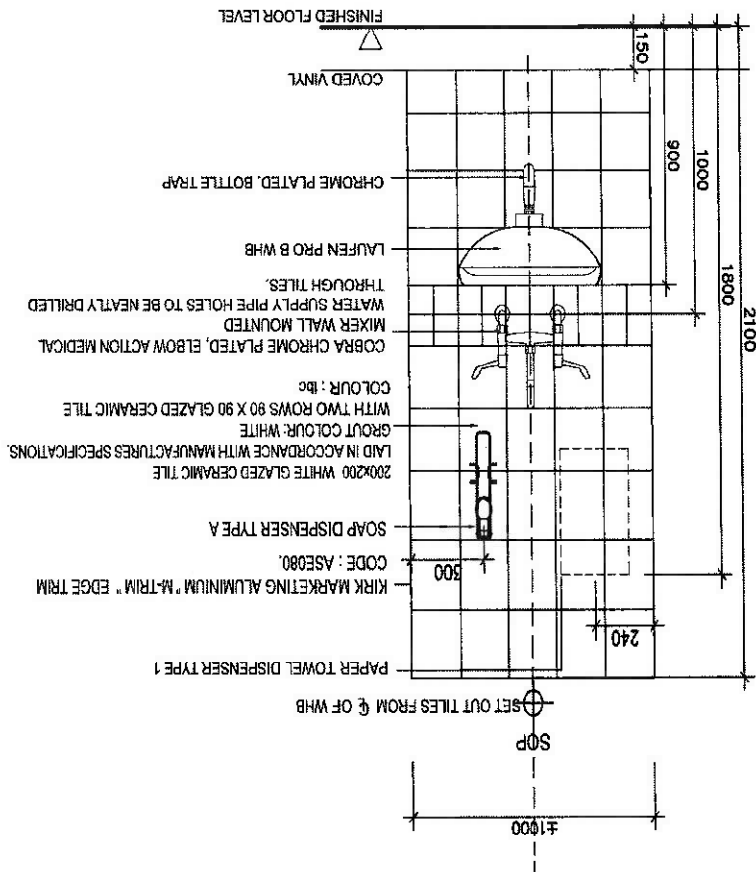

TYPICAL MEDICAL BASIN
 SOME ARRANGEMENTS MAY DIFFER

TOILET ROLL HOLDER
SERRA ROL TR2 GRADE 304 SATIN FINISH STAINLESS STEEL WITH SNAPLOCK & KEY

VAAL HIBISCUS ELITE CLOSE COUPLED SUITE COMPLETE WITH JAZZ THERMOSET TOILET
SEAT CODE 853120
PRODUCT CODE 772402 WHITE
INSTALLED IN STRICTLY ACCORDING TO MANUFACTURERS INSTRUCTIONS

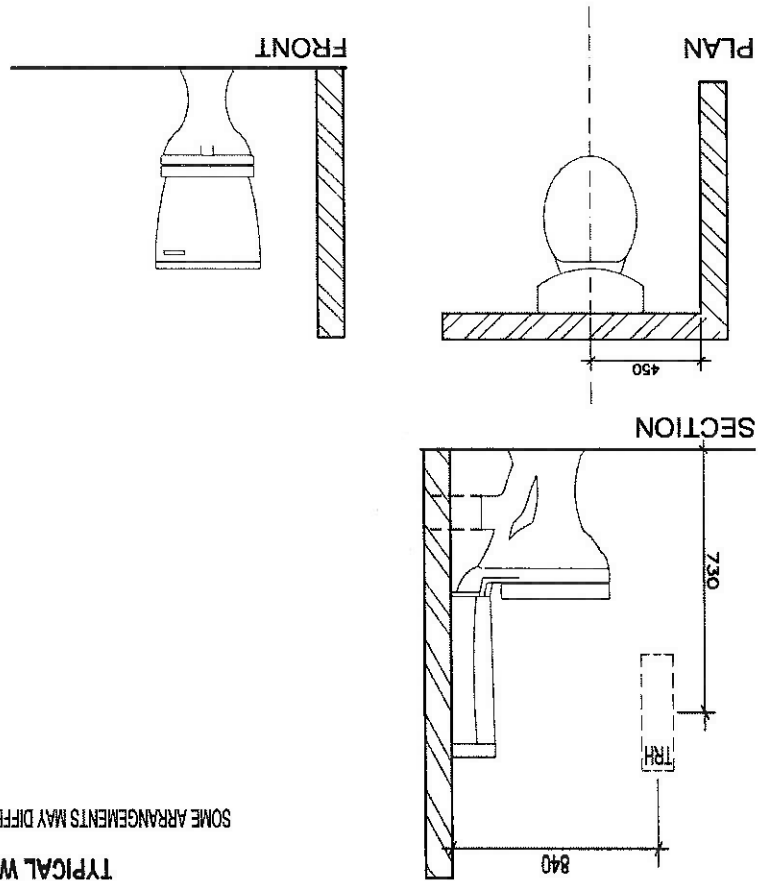

TYPICAL WC
SOME ARRANGEMENTS MAY DIFFER