

SharePoint

Hadebe Northlanhla Patient Punt - ?



KWAZULU-NATAL PROVINCE  
HEALTH  
REPUBLIC OF SOUTH AFRICA

KZN HEALTH

### KZN Health Intranet

Search this site

- HOME
- CORPORATE INFORMATION
- COMPONENTS
- DIRECTORY
- DISTRICT OFFICES
- HEALTH FACILITIES

KZN Health > Components > Supply Chain Management

AdvertQuote



KWAZULU-NATAL PROVINCE  
HEALTH  
REPUBLIC OF SOUTH AFRICA

### Quotation Advert

Opening Date: 2021-11-05

Closing Date: 2021-11-12

Closing Time: 11:00

#### INSTITUTION DETAILS

Institution Name: St Apollinaris hospital

Province: KwaZulu-Natal

Department or Entity: Department of Health

Division or section: Central Supply Chain Management

Place where goods / services is required: ST APOLLINARIS HOSPITAL

Date Submitted: 2021-11-05

#### ITEM CATEGORY AND DETAILS

Quotation Number: ZNQ: SAP 163/2021/2022

Item Category: Goods

Item Description: SUPPLY AND DELIVER UNIFORM

Quantity (if supplies)

#### COMPULSORY BRIEFING SESSION / SITE VISIT

Select Type: Select...

Date:

Time:

Venue:

QUOTES CAN BE COLLECTED FROM: WEBSITE

QUOTES SHOULD BE DELIVERED TO: TENDER BOX

#### ENQUIRIES REGARDING THE ADVERT MAY BE DIRECTED TO:

Name: MRS S.P MZIMKHULU

Email:

Contact Number: 0398339001

Finance Manager Name:

Finance Manager Signature:

MRS MB KHESWA  
PP

No late quotes will be considered





DECLARATION OF INTEREST

1. Any legal person, including persons employed by the state<sup>1</sup>, or persons having a kinship with persons employed by the state, including a blood relationship, may make an offer or offers in terms of this invitation to quote (includes a price quotation, advertised competitive quote, limited quote or proposal). In view of possible allegations of favouritism, should the resulting quote, or part thereof, be awarded to persons employed by the state or to persons connected with or related to them, it is required that the bidder or his/her authorised representative declare his/her position in relation to the evaluating/adjudicating authority where-
  - the bidder is employed by the state; and/or
  - the legal person on whose behalf the bidding document is signed, has a relationship with persons/a person who are/is involved in the evaluation and or adjudication of the quote(s), or where it is known that such a relationship exists between the person or persons for or on whose behalf the declarant acts and persons who are involved with the evaluation and or adjudication of the quote.

2. In order to give effect to the above, the following questionnaire must be completed and submitted with the quote.

- 2.1. Full Name of bidder/representative.....
- 2.2. Identity Number: .....
- 2.3. Position occupied in the Company (director, trustee, shareholder<sup>2</sup>): .....
- 2.4. Company Registration Number: .....
- 2.5. Tax Reference Number: .....
- 2.6. VAT Registration Number: .....

2.7. The names of all directors / trustees / shareholders / members, their individual identity numbers, tax reference numbers and, if applicable, employee / persal numbers must be indicated in paragraph 3 below. [TICK APPLICABLE]

2.8. Are you or any person connected with the bidder presently employed by the state? YES  NO

2.8.1. If so, furnish the following particulars:  
 Name of person / director / trustee / shareholder/ member: .....  
 Name of state institution at which you or the person connected to the bidder is employed:.....  
 Position occupied in the state institution: .....Any other particulars:.....

2.8.2. If you are presently employed by the state, did you obtain the appropriate authority to undertake remunerative work outside employment in the public sector? YES  NO

2.8.2.1. If yes, did you attach proof of such authority to the quote document? YES  NO

*(Note: Failure to submit proof of such authority, where applicable, may result in the disqualification of the quote.)*

2.8.2.2. If no, furnish reasons for non-submission of such proof: .....

2.9. Did you or your spouse, or any of the company's directors / trustees / shareholders / members or their spouses conduct business with the state in the previous twelve months? YES  NO

2.9.1. If so, furnish particulars:.....

2.10. Do you, or any person connected with the bidder, have any relationship (family, friend, other) with a person employed by the state and who may be involved with the evaluation and or adjudication of this quote? YES  NO

2.10.1. If so, furnish particulars:.....

2.11. Are you, or any person connected with the bidder, aware of any relationship (family, friend, other) between any other bidder and any person employed by the state who may be involved with the evaluation and or adjudication of this quote? YES  NO

2.11.1. If so, furnish particulars:.....

2.12. Do you or any of the directors / trustees / shareholders / members of the company have any interest in any other related companies whether or not they are bidding for this contract? YES  NO

2.12.1. If so, furnish particulars:.....

**3. Full details of directors / trustees / members / shareholders.**

NB: The Department Of Health will validate details of directors / trustees / members / shareholders on CSD. It is the suppliers' responsibility to ensure that their details are up-to-date and verified on CSD. If the Department cannot validate the information on CSD, the quote will not be considered and passed over as non-compliant according to National Treasury Instruction Note 4 (a) 2016/17.

**4 DECLARATION**

I, THE UNDERSIGNED (NAME).....CERTIFY THAT THE INFORMATION FURNISHED IN PARAGRAPHS 2.

I ACCEPT THAT THE STATE MAY REJECT THE QUOTE OR ACT AGAINST ME SHOULD THIS DECLARATION PROVE TO BE FALSE.

..... Name of bidder	..... Signature	..... Position	..... Date
-------------------------	--------------------	-------------------	---------------

<sup>1</sup>"State" means -

- |   |   |
|---|---|
| a) any national or provincial department, national or provincial public entity or constitutional institution within the meaning of the Public Finance Management Act, 1999 (Act No. 1 of 1999); | c) provincial legislature;                                    |
| b) any municipality or municipal entity;  | d) national Assembly or the national Council of provinces; or |
|   | e) Parliament.  |

<sup>2</sup>"Shareholder" means a person who owns shares in the company and is actively involved in the management of the enterprise or business and exercises control over the enterprise.

## SPECIAL CONTRACT CONDITIONS OF QUOTATIONS

### 1. AMENDMENT OF CONTRACT

- 1.1. Any amendment to or renunciation of the provisions of the contract shall at all times be done in writing and shall be signed by both parties.

### 2. CHANGE OF ADDRESS

- 2.1. Bidders must advise the Department of Health (institution where the offer was submitted) should their address (*domicilium citandi et executandi*) details change from the time of bidding to the expiry of the contract.

### 3. GENERAL CONDITIONS ATTACHED TO THIS QUOTATION

- 3.1. The Department is under no obligation to accept the lowest or any quote.
- 3.2. The Department reserves the right to communicate in writing with vendors in cases where information is incomplete or where there are obscurities regarding technical aspects of the offer, to obtain confirmation of prices or preference claims in cases where it is evident that a typing, written, transfer or unit error has been made, to investigate the vendor's standing and ability to complete the supply/service satisfactorily.
- 3.3. **ALL DECISIONS TAKEN BY THE DEPARTMENT ARE FINAL, INCLUDING THE AWARD OF THIS QUOTATION.**
- 3.4. The price quoted must include VAT (if VAT vendor). However, it must be noted that the Department reserves the right to evaluate all quotations excluding VAT as some bidders may not be VAT vendors.
- 3.5. The bidder must ensure the correctness & validity of the quotation:
- (i) *that the price(s), rate(s) & preference quoted cover all for the work/item (s) & accept that any mistakes regarding the price (s) & calculations will be at the bidder's risk*
  - (ii) *it is the responsibility of the bidder to confirm receipt of their quotation and to keep proof thereof.*
- 3.6. The bidder must accept full responsibility for the proper execution & fulfilment of all obligations conditions devolving on under this agreement, as the Principal (s) liable for the due fulfilment of this contract.
- 3.7. This quotation will be evaluated based on the 80/20 points system, specification, correctness of information and/or functionality criteria. All required documentation must be completed in full and submitted.
- 3.8. Offers must comply strictly with the specification.
- 3.9. Only offers that meet or are greater than the specification will be considered.
- 3.10. Late offers will not be considered.
- 3.11. Expired product/s will not be accepted. All products supplied must be valid for a minimum period of six months.
- 3.12. Used/ second-hand products will not be accepted.
- 3.13. A bidder not registered on the Central Suppliers Database or whose verification has failed will not be considered.
- 3.14. All delivery costs must be included in the quoted price for delivery at the prescribed destination.
- 3.15. Only firm prices will be accepted. Such prices must remain firm for the contract period. Non-firm prices (including rates of exchange variations) will not be considered.
- 3.16. In cases where different delivery points influence the pricing, a separate pricing schedule must be submitted for each delivery point.
- 3.17. In the event of a bidder having multiple quotes, only the cheapest according to specification will be considered.
- 3.18. Verification will be conducted to identify if bidders have multiple companies and are cover-quoting for this bid.
- 3.19. In such instances, the Department reserves the right to immediately disqualify such bidders as cover-quoting is an offence that represents both corruption and acquisition fraud.

### 4. SPECIAL INSTRUCTIONS AND NOTICES TO BIDDERS REGARDING THE COMPLETION OF THIS QUOTATION.

- 4.1. Unless inconsistent with or expressly indicated otherwise by the context, the singular shall include the plural and vice versa and with words importing the masculine gender shall include the feminine and the neuter.
- 4.2. Under no circumstances whatsoever may the quotation/bid forms be retyped or redrafted. Photocopies of the original bid documentation may be used, but an original signature must appear on such photocopies.
- 4.3. The bidder is advised to check the number of pages and to satisfy himself that none are missing or duplicated.
- 4.4. Quotations submitted must be complete in all respects. However, where it is identified that information in a bidder's response is incomplete in any respect, the said supplier meets all specification requirements and is lowest to quote, the Department reserves the right to request the bidder to complete/submit such information.
- 4.5. Any alteration made by the bidder must be initialled; failure to do so may render the response invalid.
- 4.6. Use of correcting fluid is prohibited and may render the response invalid.
- 4.7. Quotations will be opened in public as soon as practicable after the closing time of quotation.
- 4.8. Where practical, prices are made public at the time of opening quotations.
- 4.9. If it is desired to make more than one offer against any individual item, such offers should be given on a photocopy of the page in question. Clear indication thereof must be stated on the schedules attached.
- 4.10. The Department is under no obligation to pay suppliers in part for work done if the supplier can no longer for fulfil their obligation.

**5. SPECIAL INSTRUCTIONS REGARDING HAND DELIVERED QUOTATIONS**

- 5.1. Quotation shall be lodged at the address indicated not later than the closing time specified for their receipt, and in accordance with the directives in the quotation documents.
- 5.2. Each quotation shall be addressed in accordance with the directives in the quotation documents and shall be lodged in a separate sealed envelope, with the name and address of the bidder, the quotation number and closing date indicated on the envelope. The envelope shall not contain documents relating to any quotation other than that shown on the envelope. If this provision is not complied with, such quotations/bids may be rejected as being invalid.
- 5.3. All quotations received in sealed envelopes with the relevant quotation numbers on the envelopes are kept unopened in safe custody until the closing time of the quotation/bids. Where, however, a quotation is received open, it shall be sealed. If it is received without a quotation/bid number on the envelope, it shall be opened, the quotation number ascertained, the envelope sealed and the quotation number written on the envelope.
- 5.4. A specific box is provided for the receipt of quotations, and no quotation found in any other box or elsewhere subsequent to the closing date and time of quotation will be considered.
- 5.5. No quotation/bid sent through the post will be considered if it is received after the closing date and time stipulated in the quotation documentation, and proof of posting will not be accepted as proof of delivery.
- 5.6. Quotation documents must not be included in packages containing samples. Such quotations may be rejected as being invalid.

**6. SAMPLES**

- 6.1. In the case of the quote document stipulating that samples are required, the supplier will be informed in due course when samples should be provided to the institution. (This decreases the time of safety and storage risk that may be incurred by the respective institution). The bidders sample will be retained if such bidder wins the contract.
  - (i) If a company/s who has not won the quote requires their samples, they must advise the institution in writing of such.
  - (ii) If samples are not collected within three months of close of quote the institution reserves the right to dispose of them at their discretion.
- 6.2. **Samples must be made available when requested in writing or if stipulated on the document.**
  - (i) If a Bidder fails to provide a sample of their product on offer for scrutiny against the set specification when requested, their offer will be rejected. All testing will be for the account of the bidder.

**7. COMPULSORY SITE INSPECTION / BRIEFING SESSION**

- 7.1. Bidders who fail to attend the compulsory meeting will be disqualified from the evaluation process.

- (i) The institution has determined that a compulsory site meeting  take place
- (ii) Date \_\_\_\_/\_\_\_\_/\_\_\_\_ Time \_\_\_\_:\_\_\_\_ Place \_\_\_\_\_

Institution Stamp:	Institution Site Inspection / briefing session Official
	Full Name: .....
	Signature: .....
	Date: .....

**8. STATEMENT OF SUPPLIES AND SERVICES**

- 8.1. The contractor shall, when requested to do so, furnish particulars of supplies delivered or services executed. If he/she fails to do so, the Department may, without prejudice to any other rights which it may have, institute inquiries at the expense of the contractor to obtain the required particulars.

**9. SUBMISSION AND COMPLETION OF SBD 6.1**

- 9.1. Should a bidder wish to qualify for preference points they must complete a SBD 6.1 document. Failure by a bidder to provide all relevant information required, will result in such a bidder not being considered for preference point's allocation. The preferences applicable on the closing date will be utilized. Any changes after the closing date will not be considered for that particular quote.

**10. TAX COMPLIANCE REQUIREMENTS**

- 10.1. In the event that the tax compliance status has failed on CSD, **it is the suppliers' responsibility to provide a SARS pin in order for the institution to validate the tax compliance status of the supplier.**
- 10.2. In the event that the institution cannot validate the suppliers' tax clearance on SARS as well as the Central Suppliers Database, **the quote will not be considered and passed over as non-compliant according to National Treasury Instruction Note 4 (a) 2016/17.**

## 11. TAX INVOICE

11.1. A tax invoice shall be in the currency of the Republic of South Africa and shall contain the following particulars:

- |  |  |
|--|--|
| (i) the name, address and registration number of the supplier;                           | (iv) a description and quantity or volume of the goods or services supplied; |
| (ii) the name and address of the recipient;  | (v) the official department order number issued to the supplier;             |
| (iii) an individual serialized number and the date upon which the tax invoice is issued; | (vi) the value of the supply, the amount of tax charged;                     |
|  | (vii) the words tax invoice in a prominent place.                            |

## 12. PATENT RIGHTS

The supplier shall indemnify the **KZN Department of Health** (hereafter known as the purchaser) against all third-party claims of infringement of patent, trademark, or industrial design rights arising from use of the goods or any part thereof by the purchaser.

## 13. PENALTIES

- 13.1. If at any time during the contract period, the service provider is unable to perform in a timely manner, the service provider must notify the institution in writing/email of the cause of and the duration of the delay. Upon receipt of the notification, the institution should evaluate the circumstances and, if deemed necessary, the institution may extend the service provider's time for performance.
- 13.2. In the event of delayed performance that extends beyond the delivery period, the institution is entitled to purchase commodities of a similar quantity and quality as a substitution for the outstanding commodities, without terminating the contract, as well as return commodities delivered at a later stage at the service provider's expense.
- 13.3. Alternatively, the institution may elect to terminate the contract and procure the necessary commodities in order to complete the contract. In the event that the contract is terminated the institution may claim damages from the service provider in the form of a penalty. The service provider's performance should be captured on the service provider database in order to determine whether or not the service provider should be awarded any contracts in the future.
- 13.4. If the supplier fails to deliver any or all of the goods or to perform the services within the period(s) specified in the contract, the purchaser shall, without prejudice to its other remedies under the contract, deduct from the contract price, as a penalty, a sum calculated on the delivered price of the delayed goods or unperformed services using the current prime interest rate calculated for each day of the delay until actual delivery or performance.

## 14. TERMINATION FOR DEFAULT

- 14.1. The purchaser, without prejudice to any other remedy for breach of contract, by written notice of default sent to the supplier, may terminate this contract in whole or in part:
- (i) if the supplier fails to deliver any or all of the goods within the period(s) specified in the contract,
  - (ii) if the supplier fails to perform any other obligation(s) under the contract; or
  - (iii) if the supplier, in the judgment of the purchaser, has engaged in corrupt or fraudulent practices in competing for or in executing the contract.
- 14.2. In the event the purchaser terminates the contract in whole or in part, the purchaser may procure, upon such terms and in such manner as it deems appropriate, goods, works or services similar to those undelivered, and the supplier shall be liable to the purchaser for any excess costs for such similar goods, works or services.
- 14.3. Where the purchaser terminates the contract in whole or in part, the purchaser may decide to impose a restriction penalty on the supplier by prohibiting such supplier from doing business with the public sector for a period not exceeding 10 years.

## 15. FAILURE TO COMPLY WITH ABOVE WILL RESULT IN YOUR QUOTE BEING PASSED OVER.

**PREFERENCE POINTS CLAIM FORM IN TERMS OF THE PREFERENTIAL PROCUREMENT REGULATIONS 2017**

This preference form must form part of all quotes invited. It contains general information and serves as a claim form for preference points for Broad-Based Black Economic Empowerment (B-BBEE) Status Level of Contribution

**NB: BEFORE COMPLETING THIS FORM, BIDDERS MUST STUDY THE GENERAL CONDITIONS, DEFINITIONS AND DIRECTIVES APPLICABLE IN RESPECT OF B-BBEE, AS PRESCRIBED IN THE PREFERENTIAL PROCUREMENT REGULATIONS, 2017.**

**1. GENERAL CONDITIONS**

- 1.1 The following preference point systems are applicable to all quotes:
- the 80/20 system for requirements with a Rand value of up to R50 000 000 (all applicable taxes included); and
- 1.2 The value of this quote is estimated to not exceed R50 000 000 (all applicable taxes included) and therefore the 80/20 preference point system shall be applicable.
- 1.3 Points for this quote shall be awarded for:
- (a) Price; and
  - (b) B-BBEE Status Level of Contributor.
- 1.4 The maximum points for this quote is allocated as follows:

	<b>POINTS</b>
<b>PRICE</b>	80
<b>B-BBEE STATUS LEVEL OF CONTRIBUTOR</b>	20
<b>Total points for Price and B-BBEE must not exceed</b>	<b>100</b>

- 1.5 Failure on the part of a bidder to submit proof of B-BBEE Status level of contributor together with the quote, will be interpreted to mean that preference points for B-BBEE status level of contribution are not claimed.
- 1.6 The purchaser reserves the right to require of a bidder, either before a quote is adjudicated or at any time subsequently, to substantiate any claim in regard to preferences, in any manner required by the purchaser.

**2. DEFINITIONS**

- (a) **"B-BBEE"** means broad-based black economic empowerment as defined in section 1 of the Broad-Based Black Economic Empowerment Act;
- (b) **"B-BBEE status level of contributor"** means the B-BBEE status of an entity in terms of a code of good practice on black economic empowerment, issued in terms of section 9(1) of the Broad-Based Black Economic Empowerment Act;
- (c) **"bid"** means a written offer in a prescribed or stipulated form in response to an invitation by an organ of state for the provision of goods or services, through price quotations, advertised competitive bidding processes or proposals;
- (d) **"Broad-Based Black Economic Empowerment Act"** means the Broad-Based Black Economic Empowerment Act, 2003 (Act No. 53 of 2003);
- (e) **"EME"** means an Exempted Micro Enterprise in terms of a code of good practice on black economic empowerment issued in terms of section 9 (1) of the Broad-Based Black Economic Empowerment Act;
- (f) **"functionality"** means the ability of a tenderer to provide goods or services in accordance with specifications as set out in the tender documents.
- (g) **"prices"** includes all applicable taxes less all unconditional discounts;
- (h) **"proof of B-BBEE status level of contributor"** means:
  - 1) B-BBEE Status level certificate issued by an authorized body or person;
  - 2) A sworn affidavit as prescribed by the B-BBEE Codes of Good Practice;
  - 3) Any other requirement prescribed in terms of the B-BBEE Act;
- (i) **"QSE"** means a qualifying small business enterprise in terms of a code of good practice on black economic empowerment issued in terms of section 9 (1) of the Broad-Based Black Economic Empowerment Act;
- (j) **"rand value"** means the total estimated value of a contract in Rand, calculated at the time of bid invitation, and includes all applicable taxes;



**3. POINTS AWARDED FOR PRICE**

**3.1 THE 80/20 PREFERENCE POINT SYSTEMS**

A maximum of 80 points is allocated for price on the following basis:

$$Ps = 80 \left( 1 - \frac{Pt - P \min}{P \min} \right) \text{ Where}$$

- Ps = Points scored for price of bid under consideration
- Pt = Price of bid under consideration
- Pmin = price of lowest acceptable bid

**4. POINTS AWARDED FOR B-BBEE STATUS LEVEL OF CONTRIBUTOR**

4.1 In terms of Regulation 6 (2) and 7 (2) of the Preferential Procurement Regulations, preference points must be awarded to a bidder for attaining the B-BBEE status level of contribution in accordance with the table below:

B-BBEE Status Level of Contributor	Number of points (80/20 system)
1	20
2	18
3	14
4	12
5	8
6	6
7	4
8	2
Non-compliant contributor	0

**5. BID DECLARATION**

5.1 Bidders who claim points in respect of B-BBEE Status Level of Contribution must complete the following:

**6. B-BBEE STATUS LEVEL OF CONTRIBUTOR CLAIMED IN TERMS OF PARAGRAPHS 1.4 AND 4.1**

6.1 B-BBEE Status Level of Contributor: = .....(maximum of 20 points)

(Points claimed in respect of paragraph 7.1 must be in accordance with the table reflected in paragraph 4.1 and must be substantiated by relevant proof of B-BBEE status level of contributor.

**7. SUB-CONTRACTING applicable box**

(Tick

YES		NO	
-----	--	----	--

7.1 Will any portion of the contract be sub-contracted?

7.1.1 If yes, indicate:

- i) What percentage of the contract will be subcontracted.....%
- ii) The name of the sub-contractor.....
- iii) The B-BBEE status level of the sub-contractor.....

8. Whether the sub-contractor is an EME or QSE

(Tick applicable box)

iv) Specify, by ticking the appropriate box, if subcontracting with an enterprise in terms of Preferential Procurement Regulations,2017:

YES		NO	
-----	--	----	--

Designated Group: An EME or QSE which is at least 51% owned by:	EME	QSE
Black people	√	√
Black people who are youth		
Black people who are women		
Black people with disabilities		
Black people living in rural or underdeveloped areas or townships		
Cooperative owned by black people		
Black people who are military veterans		
OR		
Any EME		

Any QSE		
---------	--	--

9. **DECLARATION WITH REGARD TO COMPANY/FIRM**

9.1 Name of company/firm:.....

9.2 VAT registration number:.....

9.3 Company registration number:.....

9.4 TYPE OF COMPANY/ FIRM [TICK APPLICABLE BOX]

- Partnership/Joint Venture / Consortium
- One person business/sole propriety
- Close corporation
- Company
- (Pty) Limited

9.5 DESCRIBE PRINCIPAL BUSINESS ACTIVITIES

.....

9.6 COMPANY CLASSIFICATION [TICK APPLICABLE BOX]

- Manufacturer
- Supplier
- Professional service provider
- Other service providers, e.g. transporter, etc.

9.7 Total number of years the company/firm has been in business:.....

9.8 I/we, the undersigned, who is / are duly authorised to do so on behalf of the company/firm, certify that the points claimed, based on the B-BBE status level of contributor indicated in paragraphs 1.4 and 6.1 of the foregoing certificate, qualifies the company/ firm for the preference(s) shown and i / we acknowledge that:

- i) The information furnished is true and correct;
- ii) The preference points claimed are in accordance with the General Conditions as indicated in paragraph 1 of this form;
- iii) In the event of a contract being awarded as a result of points claimed as shown in paragraphs 1.4 and 6.1, the contractor may be required to furnish documentary proof to the satisfaction of the purchaser that the claims are correct;
- iv) If the B-BBEE status level of contributor has been claimed or obtained on a fraudulent basis or any of the conditions of contract have not been fulfilled, the purchaser may, in addition to any other remedy it may have –
  - (a) disqualify the person from the bidding process;
  - (b) recover costs, losses or damages it has incurred or suffered as a result of that person's conduct;
  - (c) cancel the contract and claim any damages which it has suffered as a result of having to make less favourable arrangements due to such cancellation;
  - (d) recommend that the bidder or contractor, its shareholders and directors, or only the shareholders and directors who acted on a fraudulent basis, be restricted by the National Treasury from obtaining business from any organ of state for a period not exceeding 10 years, after the *audi alteram partem* (hear the other side) rule has been applied; and
  - (e) forward the matter for criminal prosecution.

WITNESSES	
1.	.....
2.	.....

..... SIGNATURE(S) OF BIDDERS(S)
DATE: .....
ADDRESS.....
.....
.....



health

Department:  
Health  
PROVINCE OF KWAZULU-NATAL

St. Apollinaris hospital  
Off Centocow main road, Centocow, CREIGHTON, 3263  
Private Bag 206, Creighton, 3263  
Tel.: 039 833 8085 , Fax.: 039 833 8054  
Email.: mpe.malinga@kznhealth.gov.za  
www.kznhealth.gov.za

SUPPLY CHAIN MANAGEMENT

Date: 02 November 2021  
ZNQ Number:

TERMS OF REFERENCE

ITEM SPECIFICATION: supply and deliver uniform as per attached specification

Name & Surname	Designation	Signature
C.S.MBANJWA	SMO	
N. NDZALELA	SMO	
M.MTUNGWANE	O/M	
MI NTSHANGASE	SCC	

SPECIFICATION TERMS AND CONDITIONS

- Only bidders that fully meet the specification shall be considered
- The institution is under no obligation to accept the lowest or any quote
- The quality of products must be SABS / SANS/ KCS approved and a certificate of compliance must be submitted when required
- The bidder must ensure the correctness and validity quote: the prices, rates & preference quoted cover all of the work and accept that any mistake regarding with the price calculations will be at the bidder's risk
- If the information supplied is found to be incorrect or false then the KZN department of Health, in addition to the remedies it may have, may recover from the contractor all cost, losses and damages incurred by the department as a result of the award of the contract, and / or cancel the contract and claim any damages
- Defaulting suppliers in terms of delivering, will be dealt with and will be reported at Treasury
- The evaluation criteria for the quotation above R30 000 will be 80/20 for the price and points certified BBBEE certificates and original tax clearance
- Incomplete declaration of interest and quotation form will not be considered
- Orders will be cancelled if the supplier fail to meet the set standards and lead time
- All quotations requiring registration with certain Bodies must be returned together with the following:
  - Valid tax clearance
  - Proof of registration with CSD
  - CK certificate / Cipro certificate
  - CIDB registration and grading with relevant job category
  - Reference letter (from where the supplier did the same job successfully)
  - Letter of good standing
  - Current proof of registration with relevant bodies
  - Sworn statement
- All conditions indicated in the quotation form will be applicable upon evaluation, and should be attached to evaluation criteria
- Quotation form must be completed and signed in full, any omissions or incomplete information and signatures will automatically disqualify the quotation
- Bill of quantity should be fully completed and all segments must be filled per item
- A guarantee / warrantee must be provided on appliances, services and repairs
- All these conditions are binding and service providers must complied with
- Samples must be provided with documents unless indicated otherwise
- For services requiring site inspection , no late bidders will be allowed to join briefing
- It is advisable to get all necessary information before quotation closing date

Chairperson

02/11/2021  
Date

End user

02/11/21  
Date

CEO

02/11/2021  
Date

## Male and female dust coats

Dust coat blue sorting bay staff

Male: X5

Female: X2

## Navy Rain suites

Large: X10

X-large : X8

## DUST COAT TECHNICAL SPECIFICATION

**CLOSURES:** Button front

**POCKETS:** Breast pocket with pen division

Large front pockets

**STITCHING:** Double stitched stress seams

Bar tacked at stress points for extra strength

**COMFORT:** Wide back yoke for extra comfort

Back slit for easy movement

Long sleeve

$\frac{3}{4}$  lengths

Fabric: 65/35 Poly Cotton

Weight: 235gsm

Knee length

Full sleeve

Three pockets

## Rain Coat Specification

Long sleeve

Open sleeve

Press stud front

Double top-stitching throughout

Hood with adjustable draw cord

Heat sealed seams

100% Water proof Polyester PVC coated fabric

:Navy

**SHOES MALE PARABELLUM BLACK AS PER ATTACHED SPECIFICATION**

- Size 6 X 03 pairs
- Size 7 X 04 pairs
- Size 8 X 08 pairs
- Size 9 X 05 pairs
- Size 10 X 02 pairs

**SHOES FEMALE PARABELLUM BLACK AS PER ATACHED SPECIFICATION**

- Size 3 X 01 pair
- Size 4 X 02 pairs
- Size 5 X 04 pairs
- Size 6 X 11 pairs
- Size 7 X 07 pairs
- Size 8 X 01 pairs

SAMPLE FOR MALE AND  
~~\_\_\_\_\_~~ FEMALE SHOES PARABELLUM

~~\_\_\_\_\_~~ LACE-UP SHOE Black

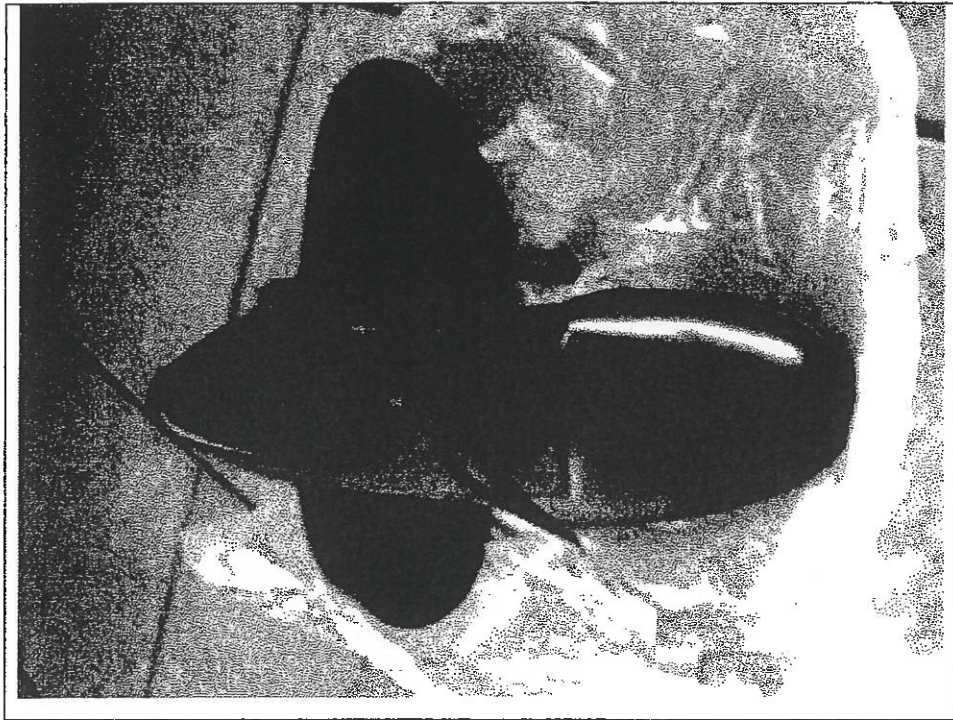

STYLE:

- ❖ RUBBER WELTED SABS SOLES
- ❖ 4 EYELETTED

SIZES: LISTED

- ❖ ~~\_\_\_\_\_~~

COLOUR:

- ❖ BLACK





**PATROLLER JACKETS SECURITY NAVY AS PER ATTACHED SPECIFICATION**

- **Patroller jackets navy security size large X 02 units**
- **Female Maroon long sleeve fleece jacket heavy weight size medium X1**
- **Female Maroon long sleeve fleece jacket heavy weight size large X2**

# SPECIFICATION FOR PATROLLER JACKETS

		gusseted back, Water repellent polyester cotton poplin material.
		<u>Size</u> 97cm                      38

	ITEM NO.	DESCRIPTION
27		PATROLLER JACKET WITH DETACHABLE LINER 102 CM NAVY  Material: 65%/35% polyester/cotton – treated for water repellence. Colour: Navy Style: shall have a concealed zip front , Two bottom pockets with flaps , Two hand warmer pockets, A badge patch, two side zips of length 21cm, Shoulder straps for epaulettes , Button out warm liner, Adjustable elasticised half belt at back, Adjustable storm cuffs, gusseted back , Water repellent polyester cotton poplin material.  <u>Size</u> 102cm                      40

	ITEM NO.	DESCRIPTION
28		PATROLLER JACKET WITH DETACHABLE LINER 107CM NAVY ✓  MATERIAL: 65% / 35% polyester/cotton – treated for water repellence.  COLOUR: Navy  STYLE: Shall have a concealed zip front, two bottom patch pockets with flaps, two hand warmer pockets, a badge patch, two side zips of length 21cm, shoulder straps for epaulettes, button out warm liner, adjustable elasticised half belt at back, adjustable storm cuffs, gusseted back, water repellent polyester cotton poplin material.  <u>Size</u> 107cm                      42

	ITEM NO.	DESCRIPTION
29		PATROLLER JACKET WITH DETACHABLE LINER 112CM NAVY

SPECIFICATION FOR SOCKS MAGNUM BLACK

Socks magnum black

X 06 Pairs

# SPECIFICATION FOR SOCKS BLACK MAGNUM

		<p><b>COLOUR:</b> White.</p> <p><b>SIZE:</b> XX-Large In accordance with CKS 34 - SABS 0188.</p> <p><b>COMPOSITION:</b> 65% polyester/35% cotton.</p> <p><b>WEAVE:</b> Plain - fully shrunk.</p> <p><b>MASS PER m<sup>2</sup>:</b> 112 gm/m<sup>2</sup>.</p> <p><b>NUMBER OF THREADS PER cm:</b> 136 x 72.</p> <p><b>YARN COUNT:</b> 45/1 x 45/1</p> <p>CREASE RESISTANT AND COLOUR FAST.</p> <p><b>STYLE:</b> Military style, epaulettes with mitred point. Jacket type with fronts of five button fastening, a glad neck collar, a double yoke, shoulder straps, two breast pockets with flaps and short sleeves with plain cuffs. The pocket flaps shall have a pen slit (left pocket only) and velcro fastenings on each corner and a mock button. Open glad neck collar shall be dual purpose, with interlining and stiffening.</p>
--	--	--

	ITEM NO.	DESCRIPTION
129	[REDACTED]	<p><b>SOCKS</b></p> <p><b>COLOUR:</b> Black. ✓</p> <p><b>COMPOSITION:</b> 65/35 Wool/Nylon.</p> <p><b>STYLE:</b> Chemically treated to prevent fungal growth, half hose with reinforced heel and toe (Knee High).</p>

	ITEM NO.	DESCRIPTION
130	[REDACTED]	<p><b>TROUSERS, GREEN COTTON FOR THEATRE</b></p> <p><b>MATERIAL:</b> Made from good quality fast dye green cotton CKS 129-40 SABS 1401 Part I and III Type P48.</p> <p><b>STYLE:</b> Waistband with cord to tie in front. <u>No</u> fly opening.</p> <p><b>SEAMS:</b> All seams raised and double stitched.</p> <p><b>POCKETS:</b> Two side pockets.</p> <p><b>TOPS:</b> Folded over 4 cm with cord secured at back (so as not to be lost).</p>

SPECIFICATION FOR EPAULLETES

Epaulettes security 1X 12mm badge gold stripe X 06 pairs

# SPECIFICATION FOR SECURITY EPAULETTES GOLD BRAID STRIPE

		<p>33. The epaulettes shall be rectangular shape. The epaulettes shall have plastic insert. The length shall be 135mm and the width at the bottom end shall be 65mm and at the top end it shall be 50mm. At the back there shall be 2 polyester straps to slide over the shoulder straps</p>
--	--	--

	ITEM NO.	DESCRIPTION
48		<p>EPAULETTES (SECURITY PERSONNEL) ✓</p> <p>Firm plastic covered in black trevira wool.</p> <p>Colour: Navy</p> <p>Composition: 55% trevira / 45% wool SABS 985 type 33</p> <p>With two loops under epaulettes. Width 65mm at shoulder tapering to 50mm at the collar end,length 135mm. With 1x12mm gold braid stripe</p>

	ITEM NO.	DESCRIPTION
49		<p>EPAULETTES (SECURITY PERSONNEL)</p> <p>Firm plastic covered in black trevira wool.</p> <p>Colour: Navy</p> <p>Composition: 55% trevira / 45% wool SABS 985 type 33</p> <p>With two loops under epaulettes. Width 65mm at shoulder tapering to 50mm at the collar end,length 135mm.</p> <p>With 2x12mm gold braid stripe</p>

	ITEM NO.	DESCRIPTION
50		<p>EPAULETTES (SECURITY PERSONNEL)</p> <p>Firm plastic covered in black trevira wool.</p> <p>Colour: navy</p> <p>Composition: 55% trevira / 45% wool SABS 985 type 33</p> <p>With two loops under epaulettes. Width 65mm at shoulder tapering to 50mm at the collar end,length 135mm. With 3x12mm gold braid stripe</p>

**SPECIFICATION FOR TIES NAVY SECURITY**

**Ties navy security**

**X 06 pairs**

# SPECIFICATION FOR TIES NAVY SECURITY 46cm

Catalogue no: 20

## NECKTIES



### STYLE:

- ❖ TO BE MADE IN THREE SECTIONS
- ❖ END TO BE MITRED POINT
- ❖ WIDE END TO BE LINED WITH LINING
- ❖ NARROW END TO BE WITH SELF FABRIC





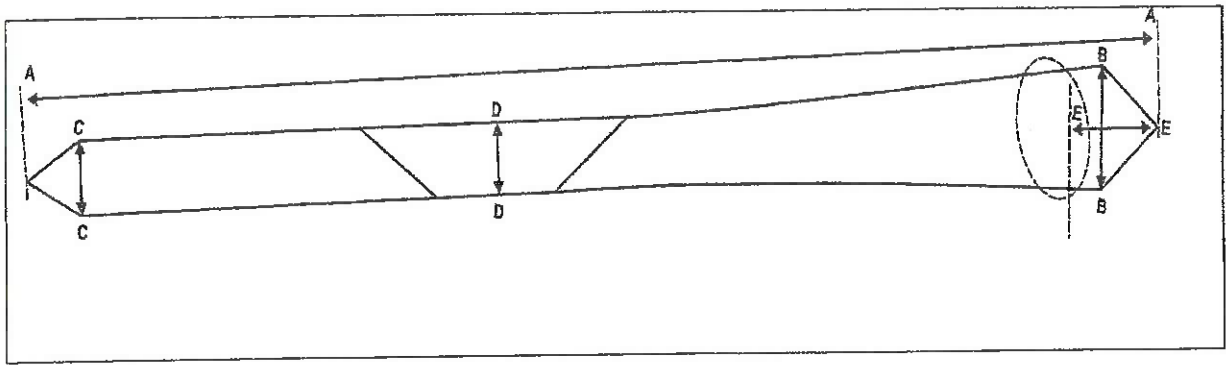

UNDERSIDE

FACE SIDE

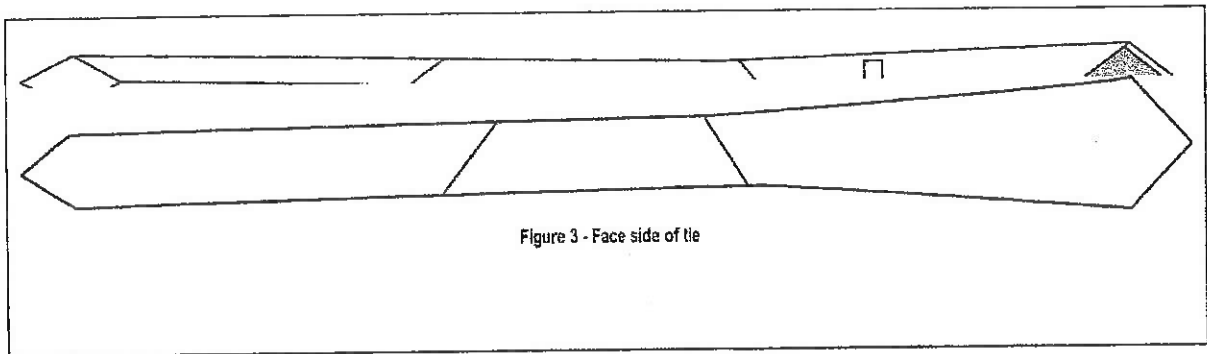

Figure 3 - Face side of tie

**OUTER FABRIC:**

- ❖ AN ACCEPTABLE POLYESTER TWILL FABRIC
- ❖ FABRIC TO COMPLY WITH RELEVANT PERFORMANCE OF SANS 1261-3-2007  
PERFORMANCE REQUIREMENTS COLOUR TO BE ACCEPTABLE MATCH IN TERMS  
OF SANS 10076-6-TUNIC BLUE.

**BODY INTERLINING:**

~~XXXXXXXXXX~~

~~XXXXXXXXXX~~

- ❖ AN ACCEPTABLE DOUBLE WEAVE INTERLINING
- ❖ HEAVY WEIGHT TO BE SUCH AS TO GIVE SUFFICIENT BODY AND STRUCTURE TO THE TIE.

**LINING:**

- ❖ AN ACCEPTABLE WOVEN POLYESTER FABRIC
- ❖ COLOUR TO BE ~~NAVY~~ NAVY 46 cm

**THREADS:**

- ❖ TO COMPLY WITH RELEVANT REQUIREMENTS OF SANS 1362 "SEWING THREADS"
- ❖ POLYESTER AND COTTON CORE SPUN OR STAPLE POLYESTER OF TICKET NO 120
- ❖ COLOUR TO BE AN ACCEPTABLE MATCH TO THE COLOUR OF THE OUTER FABRIC.

**LABEL:**

- ❖ WHITE WOVEN FABRIC LABEL THAT IS PRINTED-LOOP
- ❖ COMPLY WITH SANS 1309

**CARE LABEL:**

- ❖ LABEL TO INCLUDE COMPOSITION IN ACCORDANCE WITH THE REQUIREMENTS OF SANS 10235.

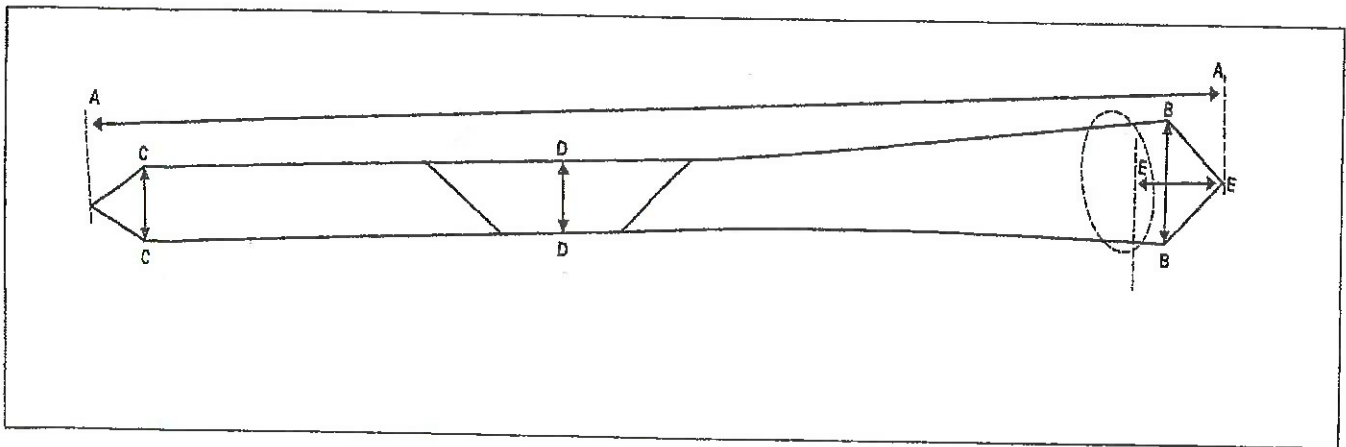

MEASURING POINT		DESCRIPTION	MEASUREMENT
A - A	TOTAL LENGTH	MEASURE FROM THE OUTER POINT OF THE NARROW END TO THE OUTER POINT OF THE WIDE SECTION.	150 CM

SPECIFICATION FOR SHOLDERS FLASH SECURITY

Shoulders flash security 7.1cm X 11cm X 06 pairs

# SPECIFICATION FOR SHOULDER FLASHES

		<b>COLOUR:</b> Navy <b>COMPOSITION:</b> 55% Trevira/ 45% New Wool <b>WEAVE:</b> Plain <b>MASS PER SQUARE METRE:</b> 260 Grams <b>NUMBER OF THREADS PER CM:</b> 46/3 X 46/3  <b>SIZE:</b> 117cm
--	--	--

	ITEM NO.	DESCRIPTION
96		<b>SHOULDER FLASHES, FOR KWAZULU-NATAL DEPARTMENT OF HEALTH.</b>  The shoulder flashes are to be made of rubberised nylon. They shall be 11 cm long and 7.1 cm wide. The colour of the background shall be navy; it shall have a slit to accommodate the shoulder strap and shall have a pin clutch backing.  <b>SIZE:</b> 11cm long and 7.1cm wide ✓

	ITEM NO.	DESCRIPTION
97		<b>TWO PIECE BOILER SUITS - ROYAL BLUE (CONTI-SUIT CKS 129-31c. Fast dye size tab to be sewn on each garment.</b>  <b>MATERIALS:</b> Type J54  <b>OUTER MATERIAL:</b> Blue Florentine Drill 100% Cotton fully shrunk 220 gm/m <sup>2</sup> . SABS 1387 Parts I and IV.  <b>ELASTIC WEBBING:</b> 6 columns of rubber strands covered by warp knit multi-filament yarns. Nominal width 40 mm and having a stretch of 120%.  <b>PRESS STUDS:</b> Open ring type of a nominal diameter of 16 mm. Manufactured of stainless steel.  <b>STYLE:</b> The suit shall consist of a jacket and long trousers.  <b>JACKET:</b> Open front type closing with 4 press studs.  <b>FOREPARTS:</b> The fore-parts shall be of shirt style with single yoke. Front edges and yoke swell stitched 10 mm from the edge.  <b>BACK:</b> The back shall be plain one piece.  <b>COLLAR:</b> Step collar 40 mm wide at the step and swell stitched 10 mm from the edge.

**TWO PIECE BOILER SUITES BLUE AS PER ATTACHED SPECIFICATION**

- Size 30 X 05 pairs
- Size 32 X 05 pairs
- Size 34 X 10 pairs
- Size 36 X 10 pairs
- Size 38 X 11 pairs
- Size 40 X 03 pairs
- Size 42 X 03 pairs
- Size 44 X 03 pairs

**TWO PIECE CONTI SUITES WHITE MALE AS PER ATTACHED SPECIFICATION**

- Size 34 X 04 pairs
- Size 36 X 02 pairs

		ALL MEASUREMENT ARE NOMINAL. SLEEVE IS MEASURED FROM CENTRE BACK TO CUFF
--	--	--

SPECIFICATION FOR TWO PIECE BOILER SUITS ROYAL BLUE AS PER SIZES

	ITEM NO.	DESCRIPTION
		<p><b>TWO PIECE BOILER SUITS - ROYAL BLUE (CONTI-SUIT): CKS 129-31c.</b> Fast dye size tab to be sewn on each garment.</p> <p><b><u>MATERIALS:</u></b> Type J54</p> <p><b><u>OUTER MATERIAL:</u></b> Blue Florentine Drill 100% Cotton fully shrunk 220 gm/m<sup>2</sup>. SABS 1387 Parts I and IV.</p> <p><b><u>ELASTIC WEBBING:</u></b> 6 columns of rubber strands covered by warp knit multi-filament yarns. Nominal width 40 mm and having a stretch of 120%.</p> <p><b><u>PRESS STUDS:</u></b> Open ring type of a nominal diameter of 16 mm. Manufactured of stainless steel.</p> <p><b><u>STYLE:</u></b> The suit shall consist of a jacket and long trousers.</p> <p><b><u>JACKET:</u></b> Open front type closing with 4 press studs.</p> <p><b><u>FOREPARTS:</u></b> The fore-parts shall be of shirt style with single yoke. Front edges and yoke swell stitched 10 mm from the edge.</p> <p><b><u>BACK:</u></b> The back shall be plain one piece.</p> <p><b><u>COLLAR:</u></b> Step collar 40 mm wide at the step and swell stitched 10 mm from the edge.</p> <p><b><u>SLEEVES:</u></b> 1 piece set-in long sleeves with 12 mm plain hemmed cuffs.</p> <p><b><u>POCKET:</u></b> Breast pocket 130 mm wide and 150 mm deep with an 8 mm hem. Single stitched to the fore-part with square corners and bar tacked at the mouth. Two lower patch pocket size 150 mm wide and 180 mm deep.</p> <p><b><u>YOKE:</u></b> Single split yoke from the shoulder seam to the lapel break.</p> <p><b><u>FACING:</u></b> The front and lapel facing of self-material 30 mm wide at the hem and 55 mm wide at the step of the collar. The raw edges of the facing over-locked and stitched to the fore-part from the shoulder seam to 40 mm below the step.</p>

**BOTTOM HEM:**

The bottom of the jacket shall be hemmed 30 mm.

**TROUSERS:**

Ruched back waist. Fully lined waist band attached with 5 rows of stitching and with 5 x 60 mm belt loops. Zip fly closing at the waist band with a plastic button. 2 laid on patch trouser pockets with slanting mouth. One plain patch hip pocket on right side. The bottoms of the trousers shall have a 5 cm hem.

**WAIST BAND:**

Waist band grown-on and lined with warp knit nylon, stitched down with 5 rows of stitching, to finish 45 mm wide. The back shall be ruched from side seam to side seam. 5 x 60mm belt loops.

**FLY:**

Front edges of the trousers over locked, turned back 30 mm and the fastener tapes attached with 2 rows of stitching. A plastic button attached at the top of the fly in the waist band.

**TROUSER**

Nominal Width of 3 mm of nickel alloy.

**POCKETS:**

A slanted opening patch side pocket single stitched to each trouser front. Pocket 115 mm deep at the side seam and 180 mm wide at the bottom. Mouth and the top and bottom of the side opening bar tacked. A plain patch hip pocket single stitched to the right back. 140 mm wide and 150 mm deep. The 15mm hem bar tacked at the corners of the mouth.

**BOTTOM HEM:**

The trousers shall have a 30 mm hem at the bottom.

**SEAMS:**

All seams of the safety stitch over lock type

**Nominal measurements of finished garment**

1. Size designation a):	97 cm
2. Circumference of chest:	114 cm
3. Circumference of seat (extended) b):	100 cm
4. Circumference of seat	112 cm
5. Circumference of plain & ruched cuff (extended) b):	28 cm
6. Circumference of knee	55 cm
7. Circumference of bottoms	50 cm
8. Length of back neck to waist:	52 cm
9. Length of outside leg:	110 cm
10. Length of inside leg:	82 cm
11. Length of set-in sleeves and raglan sleeves, long c):	49 cm
12. Length of set-in sleeves and raglan sleeves, short c):	14 cm
13. Back width d):	46 cm

- a) Based in accordance with SABS 1360-1, on the chest girth, in centimetres, of the intended wearer.
- b) The relaxed measurements of ruched cuffs and waists shall be such that there are suitable ruched for comfort and safety.
- c) Measured at the underarm seam.
- d) Not applicable to raglan sleeves.

ALL MEASUREMENT ARE NOMINAL. SLEEVE IS MEASURED FROM CENTRE BACK TO CUFF

	ITEM NO.	DESCRIPTION
[REDACTED]	[REDACTED]	<p><b>TWO PIECE BOILER SUITS - ROYAL BLUE (CONTI-SUIT): CKS 129-31c.</b> Fast dye size tab to be sewn on each garment.</p> <p><b><u>MATERIALS:</u></b> Type J54</p> <p><b><u>OUTER MATERIAL:</u></b> Blue Florentine Drill 100% Cotton fully shrunk 220 gm/m<sup>2</sup>. SABS 1387 Parts I and IV.</p> <p><b><u>ELASTIC WEBBING:</u></b> 6 columns of rubber strands covered by warp knit multi-filament yarns. Nominal width 40 mm and having a stretch of 120%.</p> <p><b><u>PRESS STUDS:</u></b> Open ring type of a nominal diameter of 16 mm. Manufactured of stainless steel.</p> <p><b><u>STYLE:</u></b> The suit shall consist of a jacket and long trousers.</p> <p><b><u>JACKET:</u></b> Open front type closing with 4 press studs.</p> <p><b><u>FOREPARTS:</u></b> The fore-parts shall be of shirt style with single yoke. Front edges and yoke swell stitched 10 mm from the edge.</p> <p><b><u>BACK:</u></b> The back shall be plain one piece.</p> <p><b><u>COLLAR:</u></b> Step collar 40 mm wide at the step and swell stitched 10 mm from the edge.</p> <p><b><u>SLEEVES:</u></b> 1 piece set-in long sleeves with 12 mm plain hemmed cuffs.</p> <p><b><u>POCKET:</u></b> Breast pocket 130 mm wide and 150 mm deep with an 8 mm hem. Single stitched to the fore-part with square corners and bar tacked at the mouth. Two lower patch pocket size 150 mm wide and 180 mm deep.</p> <p><b><u>YOKE:</u></b> Single split yoke from the shoulder seam to the lapel break.</p> <p><b><u>FACING:</u></b> The front and lapel facing of self-material 30 mm wide at the hem and 55 mm wide at the step of the collar. The raw edges of the facing over-locked and stitched to the fore-part from the shoulder</p>



# SPECIFICATION FOR TWO CONTI SUITS WHITE AS PER SIZES

		<b>BOTTOM HEM:</b>	The trousers shall have a 30mm hem at the bottom.
		<b>SEAMS:</b>	All seams of the safety stitch overlock type.
		<u>Nominal measurements of finished garment</u>	
		1. Size designation a):	92 cm
		2. Circumference of chest:	105 cm
		3 Back length :	70 cm
		4. Sleeves :	74 cm
		5. Waist size	92 cm
		6. Length of inside leg:	82.5 cm
		a) Based in accordance with SABS 1360-1, on the chest girth, in centimetres, of the intended wearer.	
		b) The relaxed measurements of ruched cuffs and waists shall be such that there are suitable ruched for comfort and safety.	
		c) Measured at the underarm seam.	
		d) Not applicable to raglan sleeves.	
		<b>ALL MEASUREMENT ARE NOMINAL. SLEEVE IS MEASURED FROM CENTRE BACK TO CUFF</b>	

	ITEM NO.	DESCRIPTION
		<b>TWO CONTI - SUITS - WHITE.</b> <span style="float: right;">✓</span> Fast dye size tab to be sewn on each garment.
		<b>MATERIALS:</b> <p style="margin-left: 20px;">Outer material: White Florentine drill 100% cotton fully shrunk 220gm/m<sup>2</sup>. Sabs 1387 parts 1 and 1v. Waist band lining: 100% nylon warp knit. Elastic webbing: 6 columns of rubber strands covered by warp knit multi-filament yarns. Nominal width 40mm and having a stretch of 120%.</p>
		<b>PRESS STUDS:</b> <p style="margin-left: 20px;">Open ring type of a nominal diameter of 16mm. Manufactured of stainless steel.</p>
		<b>STYLE:</b> <p style="margin-left: 20px;">The suit shall consist of a jacket and long trousers.</p>
		<b>JACKET:</b> <p style="margin-left: 20px;">Open front type closing with 4 press studs.</p>
		<b>FOREPARTS:</b> <p style="margin-left: 20px;">The fore-parts shall be of shirt style with single yoke. Front edges and yoke swell stitched 10mm from the edge.</p>
		<b>BACK:</b> <p style="margin-left: 20px;">The back shall be plain one piece.</p>
		<b>SLEEVES:</b> <p style="margin-left: 20px;">1 piece set-in long sleeves with 12mm plain hemmed cuffs.</p>
		<b>POCKET:</b> <p style="margin-left: 20px;">Breast pocket 130mm wide and 150mm deep with an</p>

		<p>intended wearer.</p> <p>b) The relaxed measurements of ruched cuffs and waists shall be such that there are suitable ruched for comfort and safety.</p> <p>c) Measured at the underarm seam.</p> <p>d) Not applicable to raglan sleeves.</p> <p><b>ALL MEASUREMENT ARE NOMINAL. SLEEVE IS MEASURED FROM CENTRE BACK TO CUFF</b></p>
--	--	--

	ITEM NO.	DESCRIPTION
[REDACTED]	[REDACTED]	<p><b>TWO CONTI - SUITS - WHITE.</b> Fast dye size tab to be sewn on each garment.</p> <p><b>MATERIALS:</b> Outer material: White Florentine drill 100% cotton fully shrunk 220gm/m<sup>2</sup>. Sabs 1387 parts 1 and 1v. Waist band lining: 100% nylon warp knit. Elastic webbing: 6 columns of rubber strands covered by warp knit multi-filament yarns. Nominal width 40mm and having a stretch of 120%.</p> <p><b>PRESS STUDS:</b> Open ring type of a nominal diameter of 16mm. Manufactured of stainless steel.</p> <p><b>STYLE:</b> The suit shall consist of a jacket and long trousers.</p> <p><b>JACKET:</b> Open front type closing with 4 press studs.</p> <p><b>FOREPARTS:</b> The fore-parts shall be of shirt style with single yoke. Front edges and yoke swell stitched 10mm from the edge.</p> <p><b>BACK:</b> The back shall be plain one piece.</p> <p><b>SLEEVES:</b> 1 piece set-in long sleeves with 12mm plain hemmed cuffs.</p> <p><b>POCKET:</b> Breast pocket 130mm wide and 150mm deep with an 8mm hem. Single stitched to the fore-part with square corners and bar tacked at the mouth. Two lower patch pockets size 150mm wide and 180mm deep.</p> <p><b>YOKE:</b> Single split yoke from the shoulder seam to the lapel break.</p> <p><b>FACING:</b> The front and lapel facing of self-material 30mm wide at the hem and 55mm wide at the step of the collar. The raw edges of the facing over-locked and</p>

		8mm hem. Single stitched to the fore-part with square corners and bar tacked at the mouth. Two lower patch pockets size 150mm wide and 180mm deep.
	<b>YOKE:</b>	Single split yoke from the shoulder seam to the lapel break.
	<b>FACING:</b>	The front and lapel facing of self-material 30mm wide at the hem and 55mm wide at the step of the collar. The raw edges of the facing over-locked and stitched to the fore-part from the shoulder seam to 40mm below the step.
	<b>BOTTOM HEM:</b>	The bottom of the jacket shall be hemmed 30mm.
	<b>TROUSERS:</b>	Ruched back waist. Fully lined waist band attached with 5 rows of stitching and with 5 x 60mm belt loops. Zip fly closing at the waist band with a plastic button. 2 laid on patch trouser pockets with slanting mouth, one plain patch hip pocket on right side. The bottoms of the trousers shall have a 5cm hem.
	<b>Waist band:</b>	Waist band grown -on and lined with warp knit nylon, stitched down with 5 rows of stitching, to finish 45mm wide. The back shall be ruched from side seam to side seam. 5 x 60mm belt loops.
	<b>FLY:</b>	Front edges of the trousers overlocked, turned back 30mm and the fastener tapes attached with 2 rows of stitching. A plastic button attached at the top of the fly in the waist band.
	<b>TROUSER SLIDE FASTENER:</b>	Nominal width of 3mm of nickel alloy.
	<b>POCKETS:</b>	A slanted opening patch side pocket single stitched to each trouser front. Pocket 115mm deep at the side seam and 180mm wide at the bottom. Mouth and the top and bottom of the side opening bar tacked. A plain patch hip pocket single stitched to the right back. 140mm wide and 150mm deep. The 15mm hem bar tacked at the corners of the mouth.
	<b>BOTTOM HEM:</b>	The trousers shall have a 30mm hem at the bottom.
	<b>SEAMS:</b>	All seams of the safety stitch overlock type.
	<b><u>Nominal measurements of finished garment</u></b>	
	1. Size designation a):	97 cm
	2. Circumference of chest:	110 cm
	3 Back length :	72 cm
	4. Sleeves :	76 cm
	5. Waist size	97 cm
	6. Length of inside leg:	84 cm
	a) Based in accordance with SABS 1360-1, on the chest girth, in centimetres, of the	

**WHITE UNIFORM FEMALE AS PER ATTACHED SPECIFICATION**

- Size 34 X 02 units
- Size 36 X 02 units
- Size 38 X 10 units
- Size 40 X 02 units
- Size 42 X 06 units
- Size 44 X 02 units

**SKIRTS NAVY CEREMONIAL FEMALE AS PER ATTACHED SPECIFICATION**

- Size 38 X 02 units
- Size 40 X 04 units

## SPECIFICATION FOR FEMALE WHITE UNIFORM

Cyclamen white as CKS 129/21c

MATERIAL : Polyester 65% cotton 35%. SABS 1387 part I and II, not less than 180g/m PC64.

STYLE : 7 panel princess style, open neck, front opening to below hip, short sleeves, Raglan style.

BACK : 3 panel shaped back

COLLAR : One piece collar / lapel with wide pointed corners.

FRONT : 4 panel shaped front open to below hip, top fastening by 5 buttons, top button hole 14cm from first step of lapel of collar. Two side pockets and one breast pocket for insert pens and scissors.

POCKETS : 2 slanted side pockets sewn into seams –short side 14cm long, side 19cm machine stitched, 8X4 mm tucks in pocket for attractive effect. One breast pocket on left side 6cm wide and 13.0cm long placed 7.2cm from join between front panels at sleeve seam to top of pocket.

SLEEVES : Raglan sleeve, forearm seam raised 1.25cm and double stitched , first stitching 0.3cm down and second, 1cm from edge. Underarm length 13cm.

FASTENING : Buttons equidistant down front opening to waist only.

STANDS : Buttonholes on corresponding side

BOTTOM : Unhemmed

MARKING : Size of garment to appear on label

**NB:** Please quote as per sizes requested and attached.

# SPECIFICATION FOR CEREMONIAL SKIRTS NAUJ AS PER SIZES

Catalogue no: 15

## CEREMONIAL SKIRTS - ~~COTTON~~ POLYESTER ~~COTTON~~ NAUJ

### STYLE:

- ❖ PLAIN ONE PIECE FRONT
  - WITH FOUR DARTS
- ❖ TWO-PIECE BACK
  - WITH ONE DART EACH
  - WITH SLIDE FASTENER CLOSURE
  - WITH VENT AT CENTRE BACK SEAM
- ❖ WAISTBAND
  - ELASTICISED SECTIONS AT SIDES
  - WITH BUTTON AND BUTTONHOLE CLOSURE
  - WITH BELT LOOPS

FRONT

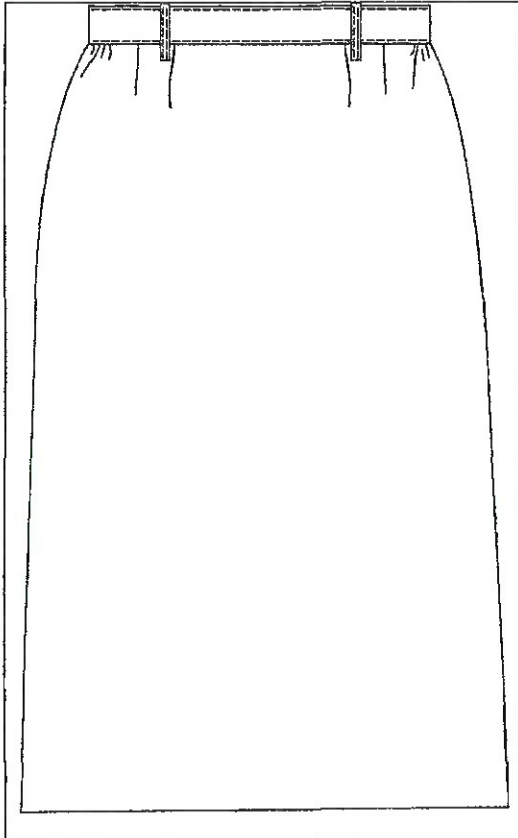

BACK

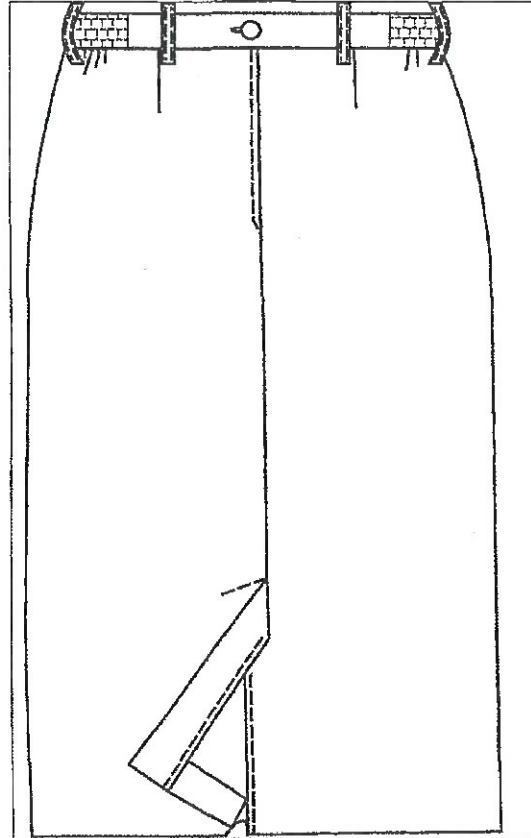

**THE OUTER FABRIC:**

- ❖ COMPLY WITH THE REQUIREMENTS FOR TYPE 33 OF SANS 985 "POLYESTER-AND-WOOL UNIFORM FABRICS."
- ❖ BE A MATCH IN TERMS OF SANS 10076-5, CKS 129 "COLOURS FOR TEXTILES – TUNIC BLUE."

**SLIDE FASTENERS:**

- ❖ ONE-WAY
- ❖ CLOSED-END
- ❖ SYNTHETIC CHAIN
- ❖ COMPLY WITH RELEVANT REQUIREMENTS OF CLASS B SLIDE FASTENERS OF SANS 1822 "SLIDE FASTENERS"
- ❖ COLOUR TO BE AN ACCEPTABLE MATCH TO THE COLOUR OF THE OUTER FABRIC.

**BUTTONS:**

- ❖ FOUR-HOLE
- ❖ PLASTICS
- ❖ DOPE-DYED
- ❖ FULLY IMPREGNATED
- ❖ OF NOMINAL DIAMETER 15mm



- ❖ COLOUR TO BE AN ACCEPTABLE MATCH TO THE COLOUR OF THE OUTER FABRIC.

**ELASTIC WEBBING:**

- ❖ TO COMPLY WITH THE REQUIREMENTS FOR TYPE 1 OF SANS 142 “NARROW ELASTIC FABRICS AND STRIP”
- ❖ OF WIDTH 30mm
- ❖ COLOUR TO BE BLACK

**SEWING THREADS:**

- ❖ TO COMPLY WITH RELEVANT REQUIREMENTS OF SANS 1362 “SEWING THREADS”
- ❖ COLOUR TO BE AN ACCEPTABLE MATCH TO THE COLOUR OF THE OUTER FABRIC.

**SEWING, TOP-STITCHING AND BUTTONHOLE THREAD:**

- ❖ POLYESTER-AND-COTTON CORE-SPUN
- ❖ TICKET NO 80

**OVER LOCKING THREAD:**

- ❖ CRIMP-TEXTURED POLYESTER
- ❖ TICKET NO 140

**SIZES:**

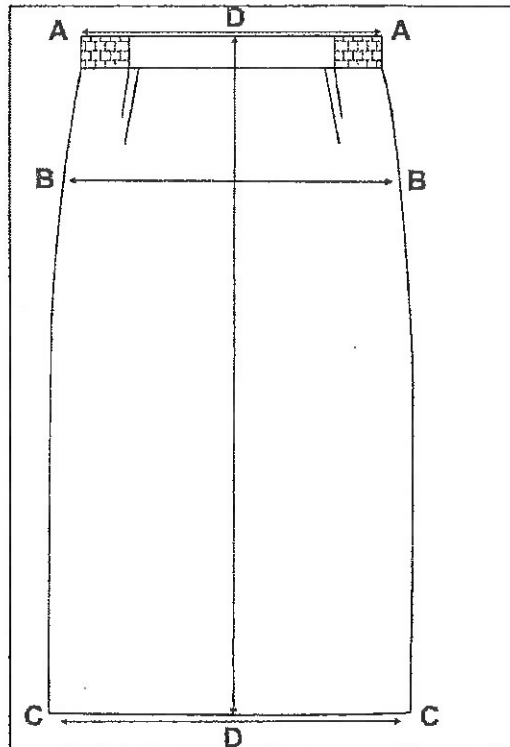

MEASURING POINT		DESCRIPTION
A - A	WAIST RELAXED	MEASURE ACROSS AT THE TOP EDGE OF THE WAISTBAND, WITHOUT STRETCHING THE WAISTBAND, AND MULTIPLY BY TWO.
A - A	WAIST EXTENDED	MEASURE ACROSS AT THE TOP EDGE OF THE WAISTBAND, STRETCHING THE WAISTBAND, AND MULTIPLY BY TWO.



**TROUSERS MALE NAVY AS PER ATTACHED SPECIFICATION**

- Size 32 X 02 units
- Size 34 X 08 units
- Size 36 X 12 units
- Size 38 X 06 units
- Size 42 X 02 units

# SPECIFICATION FOR TROUSERS MEN NAVY AS PER SIZES

		<p>slant. One jetted hip pocket with button and a fob pocket. Top quality woven polyester/cotton pocketing must be used throughout. The trousers must have a 30mm inlay at each side of the back seam. Chain stitching used on seat and side seam for extra strength. All stress points must be bar tacked throughout. All garments with finished bottoms</p> <p><b>COLOUR:</b> Navy  <b>COMPOSITION:</b> 55% Trevira/ 45% New Wool  <b>WEAVE:</b> Plain  <b>MASS PER SQUARE METRE:</b> 260 Grams  <b>NUMBER OF THREADS PER CM:</b> 46/3 X 46/3</p> <p><b>SIZE: 82cm</b></p>
--	--	--

	ITEM NO.	DESCRIPTION
		<p><b>TROUSERS MEN</b> [REDACTED]</p> <p>The trousers must have a plain waistband with 80mm bell loops to accommodate a broad belt. It must have a rubberised insert and reinforced edges. The trousers must have a zip fly and French bearer without pleats on either side of the zip. The two side pockets must slant. One jetted hip pocket with button and a fob pocket. Top quality woven polyester/cotton pocketing must be used throughout. The trousers must have a 30mm inlay at each side of the back seam. Chain stitching used on seat and side seam for extra strength. All stress points must be bar tacked throughout. All garments with finished bottoms</p> <p><b>COLOUR:</b> Navy  <b>COMPOSITION:</b> 55% Trevira/ 45% New Wool  <b>WEAVE:</b> Plain  <b>MASS PER SQUARE METRE:</b> 260 Grams  <b>NUMBER OF THREADS PER CM:</b> 46/3 X 46/3</p> <p><b>SIZE: 87cm</b></p>

		<p><b>DESCRIPTION</b></p>
		<p><b>TROUSERS MEN</b> [REDACTED]</p> <p>The trousers must have a plain waistband with 80mm bell loops to accommodate a broad belt. It must have a rubberised insert and reinforced edges. The trousers must have a zip fly and French bearer without pleats on either side of the zip. The two side pockets must slant. One jetted hip pocket with button and a fob pocket. Top quality woven polyester/cotton pocketing must be used throughout. The trousers must have a 30mm inlay at each side of the back seam. Chain stitching used on seat and side seam for extra</p>

**LIST FOR WHITE SHIRTS MALE SHORT SLEEVES AS PER ATTACHED SPECIFICATION**

- Size Medium X 10 units
- Size Large X 14 units
- Size XXLarge X 02 units

**WHITE SHIRTS FEMALE SHORT SLEEVES AS PER ATTACHED SPECIFICATION**

- Size Large X 06Female units
- Size XLarge X 03 units

**SHIRTS SECURITY MAZARIN BLUE AS PER ATTACHED SPECIFICATION**

- Shirts security long sleeves Mazarin blue 44cm X 02 units
- Shirts security long sleeves Mazarin blue 43cm X 02 units
- Shirts security short sleeves Mazarin blue size large X 02 units

	<u>COLLAR SIZE:</u>	45 cm
	<u>SLEEVE SIZE:</u>	89 cm

SPECIFICATION FOR SHIRTS MALE AND FEMALE WHITE, SHORT SLEEVES AS PER DIFF. SIZES.

ITEM NO.	DESCRIPTION
	<p><b>SHIRTS, SHORT SLEEVE</b></p> <p><u>MATERIAL:</u> Polyester/Cotton. Type P070 or P071.</p> <p><u>COLOUR:</u> White.</p> <p><u>SIZE:</u> Small In accordance with CKS 34 - SABS 0188.</p> <p><u>COMPOSITION:</u> 65% polyester/35% cotton.</p> <p><u>WEAVE:</u> Plain - fully shrunk.</p> <p><u>MASS PER m<sup>2</sup>:</u> 112 gm/m<sup>2</sup>.</p> <p><u>NUMBER OF THREADS PER cm:</u> 136 x 72.</p> <p><u>YARN COUNT:</u> 45/1 x 45/1</p> <p><b>CREASE RESISTANT AND COLOUR FAST.</b></p> <p><u>STYLE:</u> Military style, epaulettes with mitred point. Jacket type with fronts of five button fastening, a glad neck collar, a double yoke, shoulder straps, two breast pockets with flaps and short sleeves with plain cuffs. The pocket flaps shall have a pen slit (left pocket only) and velcro fastenings on each corner and a mock button. Open glad neck collar shall be dual purpose, with interlining and stiffening.</p>

ITEM NO.	DESCRIPTION
	SHIRTS, SHORT SLEEVE

		<p><b><u>MATERIAL:</u></b> Polyester/Cotton. Type P070 or P071.</p> <p><b><u>COLOUR:</u></b> White.</p> <p><b><u>SIZE:</u></b> Medium In accordance with CKS 34 - SABS 0188.</p> <p><b><u>COMPOSITION:</u></b> 65% polyester/35% cotton.</p> <p><b><u>WEAVE:</u></b> Plain - fully shrunk.</p> <p><b><u>MASS PER m<sup>2</sup>:</u></b> 112 gm/m<sup>2</sup>.</p> <p><b><u>NUMBER OF THREADS PER cm:</u></b> 136 x 72.</p> <p><b><u>YARN COUNT:</u></b> 45/1 x 45/1</p> <p>CREASE RESISTANT AND COLOUR FAST.</p> <p><b><u>STYLE:</u></b> Military style, epaulettes with mitred point. Jacket type with fronts of five button fastening, a glad neck collar, a double yoke, shoulder straps, two breast pockets with flaps and short sleeves with plain cuffs. The pocket flaps shall have a pen slit (left pocket only) and velcro fastenings on each corner and a mock button. Open glad neck collar shall be dual purpose, with interlining and stiffening.</p>
--	--	--

	ITEM NO.	DESCRIPTION
		<p>SHIRTS, SHORT SLEEVE</p> <p><b><u>MATERIAL:</u></b> Polyester/Cotton. Type P070 or P071.</p> <p><b><u>COLOUR:</u></b> White.</p> <p><b><u>SIZE:</u></b> Large In accordance with CKS 34 - SABS 0188.</p> <p><b><u>COMPOSITION:</u></b> 65% polyester/35% cotton.</p> <p><b><u>WEAVE:</u></b> Plain - fully shrunk.</p> <p><b><u>MASS PER m<sup>2</sup>:</u></b> 112 gm/m<sup>2</sup>.</p> <p><b><u>NUMBER OF THREADS PER cm:</u></b> 136 x 72.</p> <p><b><u>YARN COUNT:</u></b> 45/1 x 45/1</p> <p>CREASE RESISTANT AND COLOUR FAST.</p> <p><b><u>STYLE:</u></b> Military style, epaulettes with mitred point. Jacket</p>

		type with fronts of five button fastening, a glad neck collar, a double yoke, shoulder straps, two breast pockets with flaps and short sleeves with plain cuffs. The pocket flaps shall have a pen slit (left pocket only) and velcro fastenings on each corner and a mock button. Open glad neck collar shall be dual purpose, with interlining and stiffening.
--	--	--

ITEM NO.	DESCRIPTION
	<p><b>SHIRTS, SHORT SLEEVE</b></p> <p><b><u>MATERIAL:</u></b> Polyester/Cotton. Type P070 or P071.</p> <p><b><u>COLOUR:</u></b> White.</p> <p><b><u>SIZE:</u></b> X-Large In accordance with CKS 34 - SABS 0188.</p> <p><b><u>COMPOSITION:</u></b> 65% polyester/35% cotton.</p> <p><b><u>WEAVE:</u></b> Plain - fully shrunk.</p> <p><b><u>MASS PER m<sup>2</sup>:</u></b> 112 gm/m<sup>2</sup>.</p> <p><b><u>NUMBER OF THREADS PER cm:</u></b> 136 x 72.</p> <p><b><u>YARN COUNT:</u></b> 45/1 x 45/1</p> <p><b>CREASE RESISTANT AND COLOUR FAST.</b></p> <p><b><u>STYLE:</u></b> Military style, epaulettes with mitred point. Jacket type with fronts of five button fastening, a glad neck collar, a double yoke, shoulder straps, two breast pockets with flaps and short sleeves with plain cuffs. The pocket flaps shall have a pen slit (left pocket only) and velcro fastenings on each corner and a mock button. Open glad neck collar shall be dual purpose, with interlining and stiffening.</p>

ITEM NO.	DESCRIPTION
128	<p><b>SHIRTS, SHORT SLEEVE</b></p> <p><b><u>MATERIAL:</u></b> Polyester/Cotton. Type P070 or P071.</p>

**SPECIFICATION FOR SHIRTS SECURITY  
MAZARIN BLUE LS/SS**

	<b>MASS:</b> 115 GRAM Per Square Meter
	<b>SIZE:</b> 42CM

ITEM NO.	DESCRIPTION
70	<p><b>SHIRTS, LONG SLEEVE (SECURITY PERSONNEL)</b></p> <p>The shirt shall have a one piece collar with long sleeves and shoulder straps for epaulettes. Epaulettes to have button holes at collar end. Two breast pockets with velcro tipped miters flaps with false button on flap. All buttons have four holes and the collar, epaulettes and pocket flaps are to be top stitched.</p> <p><b>COLOUR:</b> Mazarine Blue</p> <p><b>COMPOSITION:</b> 65/35 Poplin Weave</p> <p><b>MASS:</b> 115 GRAM Per Square Meter</p> <p><b>SIZE:</b> 43CM ✓</p>

ITEM NO.	DESCRIPTION
71	<p><b>SHIRTS, LONG SLEEVE (SECURITY PERSONNEL)</b></p> <p>The shirt shall have a one piece collar with long sleeves and shoulder straps for epaulettes. Epaulettes to have button holes at collar end. Two breast pockets with velcro tipped miters flaps with false button on flap. All buttons have four holes and the collar, epaulettes and pocket flaps are to be top stitched.</p> <p><b>COLOUR:</b> Mazarine Blue</p> <p><b>COMPOSITION:</b> 65/35 Poplin Weave</p> <p><b>MASS:</b> 115 GRAM Per Square Meter</p> <p><b>SIZE:</b> 44CM ✓</p>

ITEM NO.	DESCRIPTION
72	<p><b>SHIRTS, LONG SLEEVE (SECURITY PERSONNEL)</b></p> <p>The shirt shall have a one piece collar with long sleeves and shoulder straps for epaulettes. Epaulettes to have button holes at collar end. Two breast pockets with velcro tipped miters flaps with false button on flap. All buttons have four holes and the collar, epaulettes and pocket flaps are to be top stitched.</p> <p><b>COLOUR:</b> Mazarine Blue</p> <p><b>COMPOSITION:</b> 65/35 Poplin Weave</p> <p><b>MASS:</b> 115 GRAM Per Square Meter</p> <p><b>SIZE:</b> 46CM</p>



		<p>tipped mitred flaps with false button on flap. The left. Hand top pocket flap to have a pen-hole slit. Epaulettes to have button holes at collar end. All buttons have four holes and the collar, epaulettes and pocket flaps are to be top stitched, left hand pocket slightly enlarged to cater for a pocket book to be comfortably inserted.</p> <p>COLOUR: Mazarine Blue</p> <p>COMPOSITION: 65/35 Poplin Weave</p> <p>MASS: 115 Gram Per Square Meter</p>
--	--	---

ITEM NO.	DESCRIPTION
	<p><b>SHIRTS, SHORT SLEEVE (SECURITY PERSONNEL) MEDIUM</b></p> <p>Open collar, glad neck style with shoulder straps for epaulettes and short sleeves with plain hemmed cuff. The shirt shall have two military style breast pockets with velcro tipped mitred flaps with false button on flap. The left Hand top pocket flap to have a pen-hole slit. Epaulettes to have button holes at collar end. All buttons have four holes and the collar, epaulettes and pocket flaps are to be top stitched, left hand pocket slightly enlarged to cater for a pocket book to be comfortably inserted.</p> <p>COLOUR: Mazarine Blue</p> <p>COMPOSITION: 65/35 Poplin Weave</p> <p>MASS: 115 Gram Per Square Meter</p>

ITEM NO.	DESCRIPTION
	<p><b>SHIRTS, SHORT SLEEVE (SECURITY PERSONNEL) LARGE</b> ✓</p> <p>Open collar, glad neck style with shoulder straps for epaulettes and short sleeves with plain hemmed cuff. The shirt shall have two military style breast pockets with velcro tipped mitred flaps with false button on flap. The left Hand top pocket flap to have a pen-hole slit. Epaulettes to have button holes at collar end. All buttons have four holes and the collar, epaulettes and pocket flaps are to be top stitched, left hand pocket slightly enlarged to cater for a pocket book to be comfortably inserted.</p> <p>COLOUR: Mazarine Blue</p> <p>COMPOSITION: 65/35 Poplin Weave</p> <p>MASS: 115 Gram Per Square Meter</p>



**JERSEYS MALE NAVY V- NECK AS PER ATTACHED SPECIFICATION**

- Size small X 02 units
- Size Medium X 10 units
- Size Large X 10 units
- Size XXLarge X 02 units

**FEMALE NAVY CARDIGANS PLAIN WITH KNOBS AND POCKETS AS PER ATTACHED SPECIFICATION AND PICTURES**

- Size small X 08 units
- Size medium X 22 units
- Size large X 18 units

**JERSEYS MALE NAVY SECURITY V NECK**

- Jersey male navy security size medium X 01 unit
- Jersey male navy security size large X 01 unit

( SPECIFICATION FOR JERSEY MALE NAVY AS PER SIZES

41	[REDACTED]	<p><b>JERSEY MALE NAVY V-NECK</b></p> <p><b>KNITTED FABRIC:</b> The body and sleeve would be knitted in 100% worsted spun high bulk acrylic. The weight of the fabric would be 360 grams per square meter. The constructions of the fabric would be double jersey.</p> <p><b>STYLE:</b> The jersey shall be a V-neck with long sleeve in the colour navy.</p> <p><b>BODY:</b> The body of the jersey shall consist of a front and a back panel that are seamed together at the side seams. The lower edge of the body shall have a blind stitched double welt ribbing. Overclocking of the side seams to be bar tacked. Finished with of welt to 70mm.</p> <p><b>SLEEVE:</b> The sleeves shall be one piece set in sleeves with double cuffs blind stitched and bar tacked with a finished width of 70mm. Neck opening: the neck opening shall form a V-neck at centre front and shall be finished off with 30mm trim to be mock linked.</p> <p><b>SIZE: SMALL</b></p>
----	------------	--

	ITEM NO.	DESCRIPTION
42	[REDACTED]	<p><b>JERSEY MALE NAVY V-NECK</b></p> <p><b>KNITTED FABRIC:</b> The body and sleeve would be knitted in 100% worsted spun high bulk acrylic. The weight of the fabric would be 360 grams per square metre. The constructions of the fabric would be double jersey.</p> <p><b>STYLE:</b> The jersey shall be a V-neck with long sleeve in the colour navy.</p> <p><b>BODY:</b> The body of the jersey shall consist of a front and a back panel that are seamed together at the side seams. The lower edge of the body shall have a blind stitched double welt ribbing. Overclocking of the side seams to be bar tacked. Finished with of welt to 70mm.</p> <p><b>SLEEVE:</b> The sleeves shall be one piece set in sleeves with double cuffs blind stitched and bar tacked with a finished width of 70mm. Neck opening: the neck opening shall form a V-neck at centre front and shall be finished off with 30mm trim to be mock linked.</p> <p><b>SIZE: MEDIUM</b></p>

	ITEM NO.	DESCRIPTION
--	----------	-------------

[REDACTED]

43	[REDACTED]	<p><b>JERSEY MALE NAVY V-NECK</b></p> <p><b>KNITTED FABRIC:</b> The body and sleeve would be knitted in 100% worsted spun high bulk acrylic. The weight of the fabric would be 360 grams per square meter. The constructions of the fabric would be double jersey.</p> <p><b>STYLE:</b> The jersey shall be a V-neck with long sleeve in the colour navy.</p> <p><b>BODY:</b> The body of the jersey shall consist of a front and a back panel that are seamed together at the side seams. The lower edge of the body shall have a blind stitched double welt ribbing. Overclocking of the side seams to be bar tacked. Finished with of welt to 70mm.</p> <p><b>SLEEVE:</b> The sleeves shall be one piece set in sleeves with double cuffs blind stitched and bar tacked with a finished width of 70mm. Neck opening: the neck opening shall form a V-neck at centre front and shall be finished off with 30mm trim to be mock linked.</p> <p><b>SIZE: LARGE</b></p>
----	------------	--

	ITEM NO.	DESCRIPTION
44	[REDACTED]	<p><b>JERSEY MALE NAVY V-NECK</b></p> <p><b>KNITTED FABRIC:</b> The body and sleeve would be knitted in 100% worsted spun high bulk acrylic. The weight of the fabric would be 360 grams per square meter. The constructions of the fabric would be double jersey.</p> <p><b>STYLE:</b> The jersey shall be a V-neck with long sleeve in the colour navy.</p> <p><b>BODY:</b> The body of the jersey shall consist of a front and a back panel that are seamed together at the side seams. The lower edge of the body shall have a blind stitched double welt ribbing. Overclocking of the side seams to be bar tacked. Finished with of welt to 70mm.</p> <p><b>SLEEVE:</b> The sleeves shall be one piece set in sleeves with double cuffs blind stitched and bar tacked with a finished width of 70mm. Neck opening: the neck opening shall form a V-neck at centre front and shall be finished off with 30mm trim to be mock linked.</p> <p><b>SIZE: X-LARGE</b></p>

	ITEM NO.	DESCRIPTION
		[REDACTED]

Specification for Female Cardigan  
NAVY PLAIN

ITEM NO.	DESCRIPTION
35	<p><b>LADIES CARDIGAN WITH PATCH POCKETS – SMALL</b></p> <p><b>KNITTED FABRIC:</b> The body and sleeve would be knitted in 100% worsted spun high bulk acrylic. The weight of the fabric would be 380 grams per square meter. The constructions of the fabric would be half-milano. The edge of body and sleeve would be tubular.</p> <p><b>STYLE:</b> The cardigan shall be a ladies inset sleeve with buttons and patch pockets.</p> <p><b>BODY:</b> The body of the jersey shall consist of a front and a back panel that are seamed together at the side seams. The lower edge of the body shall be 30mm of tubular edge. Overclocking of the side seams to be to be bar tacked. Finished with of tubular edge welt to 30mm.</p> <p><b>SLEEVE:</b> The sleeves shall be one piece set in sleeves with a tubular edge of 30mm.the front of the cardigan shall have buttons and patch pockets.</p> <p><b>COLOUR :</b> Navy</p>

ITEM NO.	DESCRIPTION
[REDACTED]	<p><b>LADIES CARDIGAN WITH PATCH POCKETS – MEDIUM</b></p> <p><b>KNITTED FABRIC:</b> The body and sleeve would be knitted in 100% worsted spun high bulk acrylic. The weight of the fabric would be 380 grams per square meter. The constructions of the fabric would be half-milano. The edge of body and sleeve would be tubular.</p> <p><b>STYLE:</b> The cardigan shall be a ladies inset sleeve with buttons and patch pockets.</p> <p><b>BODY:</b> The body of the jersey shall consist of a front and a back panel that are seamed together at the side seams. The lower edge of the body shall be 30mm of tubular edge. Overclocking of the side seams to be to be bar tacked. Finished with of tubular edge welt to 30mm.</p> <p><b>SLEEVE:</b> The sleeves shall be one piece set in sleeves with a tubular edge of 30mm.the front of the cardigan shall have buttons and patch pockets.</p> <p><b>COLOUR :</b> Navy</p>



Specification For Female Cardigan's  
NAVY Plain

	ITEM NO.	DESCRIPTION
37	[REDACTED]	<p><b>LADIES CARDIGAN WITH PATCH POCKETS – LARGE</b></p> <p><b>KNITTED FABRIC:</b> The body and sleeve would be knitted in 100% worsted spun high bulk acrylic. The weight of the fabric would be 380 grams per square meter. The constructions of the fabric would be half-milano. The edge of body and sleeve would be tubular.</p> <p><b>STYLE:</b> The cardigan shall be a ladies inset sleeve with buttons and patch pockets.</p> <p><b>BODY:</b> The body of the jersey shall consist of a front and a back panel that are seamed together at the side seams. The lower edge of the body shall be 30mm of tubular edge. Overclocking of the side seams to be to be bar tacked. Finished with of tubular edge welt to 30mm.</p> <p><b>SLEEVE:</b> The sleeves shall be one piece set in sleeves with a tubular edge of 30mm.the front of the cardigan shall have buttons and patch pockets.</p> <p><b>COLOUR :</b> Navy</p>

	ITEM NO.	DESCRIPTION
[REDACTED]	[REDACTED]	<p><b>LADIES CARDIGAN WITH PATCH POCKETS -X LARGE</b></p> <p><b>KNITTED FABRIC:</b> The body and sleeve would be knitted in 100% worsted spun high bulk acrylic. The weight of the fabric would be 380 grams per square meter. The constructions of the fabric would be half-milano. The edge of body and leeve would be tubular.</p> <p><b>STYLE:</b> The cardigan shall be a ladies inset sleeve with buttons and patch pockets.</p> <p><b>BODY:</b> The body of the jersey shall consist of a front and a back panel that are seamed together at the side seams. The lower edge of the body shall be 30mm of tubular edge. Overclocking of the side seams to be to be bar tacked. Finished with of tubular edge welt to 30mm.</p> <p><b>SLEEVE:</b> The sleeves shall be one piece set in sleeves with a tubular edge of 30mm.the front of the cardigan shall have buttons and patch pockets.</p> <p><b>COLOUR :</b> Navy</p>



Sample for Female Cardigans  
with pockets plain navy

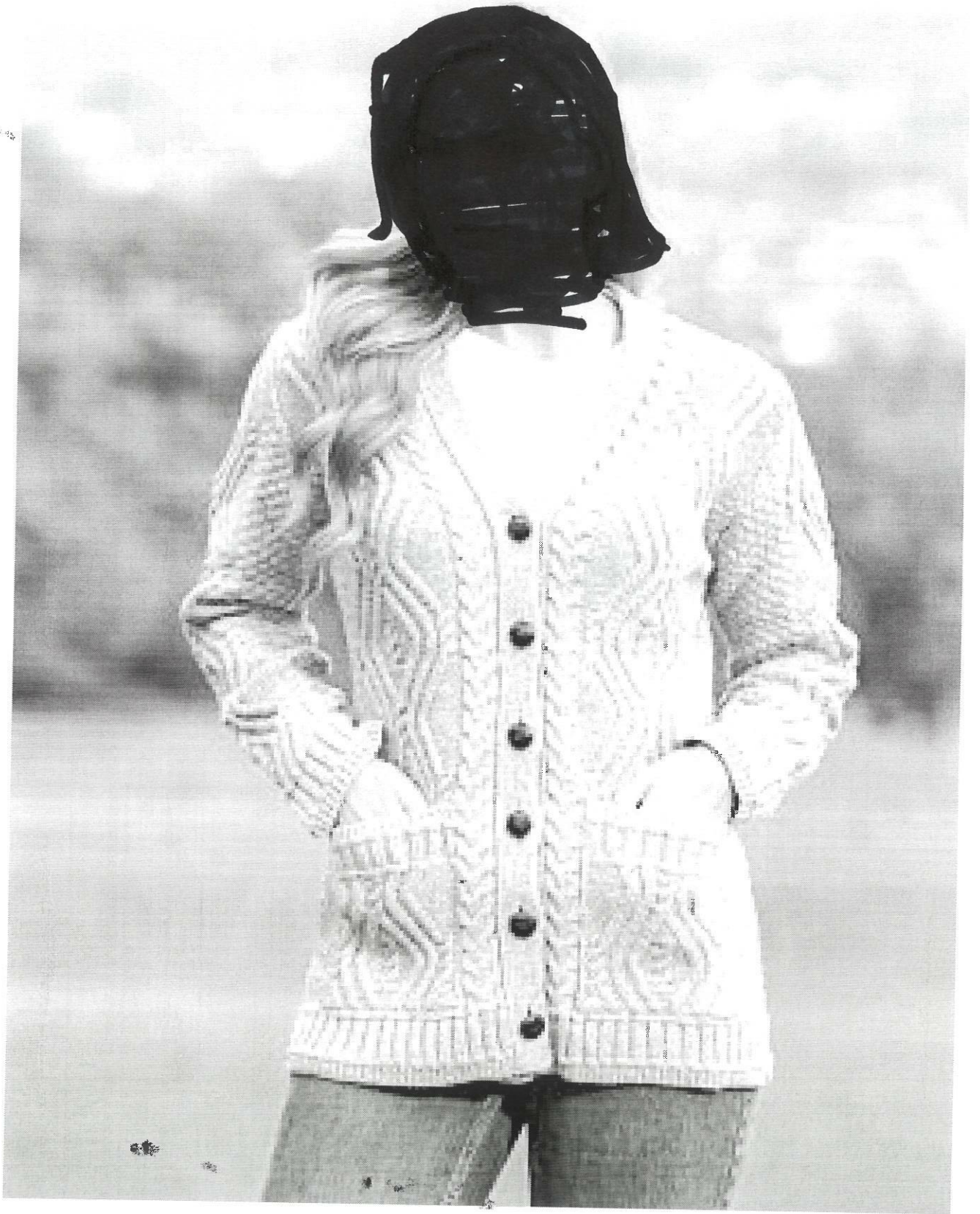



Sample for navy plain female  
cavaliers with pockets

SPECIFICATION FOR JERSEYS SECURITY  
NAVY AS PER SIZE.

	ITEM NO.	DESCRIPTION
51	[REDACTED]	<p>EPAULETTES (SECURITY PERSONNEL)</p> <p>Firm plastic covered in black trevira wool.            Colour: Navy            Composition: 55% trevira / 45% wool            SABS 985 type 33            With two loops under epaulettes. Width 65mm at shoulder tapering to 50mm at the collar end, length 135mm.</p> <p>With 4x12mm gold braid stripe ✓</p>





	ITEM NO.	DESCRIPTION
52	[REDACTED]	<p>JERSEY (SECURITY PERSONNEL)</p> <p>V-neck ribbed jersey. 1 x 1 rib, double welt cuffs, elbow patches and shoulder straps.</p> <p>COLOUR: Navy</p> <p>COMPOSITION: 100% high bulk acrylic</p> <p>SIZE: SMALL</p>

	ITEM NO.	DESCRIPTION
53	[REDACTED]	<p>JERSEY (SECURITY PERSONNEL)</p> <p>V-neck ribbed jersey. 1 x 1 rib, double welt cuffs, elbow patches and shoulder straps.</p> <p>COLOUR: Navy</p> <p>COMPOSITION: 100% high bulk acrylic</p> <p>SIZE: MEDIUM ✓</p>

	ITEM NO.	DESCRIPTION
54	[REDACTED]	JERSEY (SECURITY PERSONNEL)



		<p>V-neck ribbed jersey. 1 x 1 rib, double welt cuffs, elbow patches and shoulder straps.</p> <p>COLOUR: Navy</p> <p>COMPOSITION: 100% high bulk acrylic</p> <p>SIZE: LARGE ✓</p>
--	--	---

	ITEM NO.	DESCRIPTION
55		<p><b>JERSEY (SECURITY PERSONNEL)</b></p> <p>V-neck ribbed jersey. 1 x 1 rib, double welt cuffs, elbow patches and shoulder straps.</p> <p>COLOUR: Navy</p> <p>COMPOSITION: 100% high bulk acrylic</p> <p>SIZE: X-LARGE</p>
	ITEM NO.	DESCRIPTION
56		<p><b>JERSEY (SECURITY PERSONNEL)</b></p> <p>V-neck ribbed jersey. 1 x 1 rib, double welt cuffs, elbow patches and shoulder straps.</p> <p>Colour: Navy</p> <p>Composition: 100% high bulk acrylic</p> <p>XX Large</p>

	ITEM NO.	DESCRIPTION
57		<p><b>JERSEY (SECURITY PERSONNEL)</b></p> <p>V-neck ribbed jersey. 1 x 1 rib, double welt cuffs, elbow patches and shoulder straps.</p> <p>Colour: Navy</p> <p>Composition: 100% high bulk Acrylic</p> <p>XXX Large</p>

	ITEM NO.	DESCRIPTION
58		<p><b>SHIRTS, SHORT SLEEVE (SECURITY PERSONNEL) SMALL</b></p> <p>Open collar, glad neck style with shoulder straps for epaulettes and short sleeves with plain hemmed cuff. The shirt shall have two military style breast pockets with velcro</p>

**GUM BOOTS MALE BLACK AS PER ATTACHED SPECIFICATION**

- Size 6 X 01 pair
- Size 7 X 01 pair
- Size 8 X 01 pair
- Size 9 X 01 pair

**GUM BOOTS FEMALE BLACK AS PER ATTACHED SPECIFICATION**

- Size 7 X 01 pair
- Size 8 X 01 pair

**SAFETY BOOTS BLACK AS PER ATTACHED SPECIFICATION**

- Size 5 X 04 pairs
- Size 6 X 06 pairs
- Size 7 X 07 pairs
- Size 8 X 04 pairs
- Size 9 X 03 pairs
- Size 10 X 01 pair

**Upper: full grain leather, 3 pair D ring lace up with hooks, padded tongue and collar for comfort**

**Lining: Needle-fibred vamp lining for excellent perspiration absorbency, anti static, non-woven in sock for flexibility, comfort and stability.**

**Midsole: Shank reinforcement for arch support, steel toe cap, leather upper, slip resistant, heat resistant up to 95 degrees celcius, genuine leather.**

**Sole: Dual density PU/PU**

	<b>SEAMS:</b> All seams raised and double-stitched. GABS 0101.			
	<b>SEWING:</b> All sewing to be of spun polyester M60.			
	<b>MARKING:</b> Fast dye size tab to be sewn on each garment.			
	<b>SIZE:</b> The bottom of the jacket shall be hemmed 30 mm.			
	<b>Waist size</b>	<b>Waist Extended</b>	<b>Leg Inside</b> cm	<b>Side Seam</b>
		cm		cm
	117	125 cm	80 cm	112 cm
				<b>Bottoms</b> cm
				47 cm

## SPECIFICATION

### DEPARTMENT OF HEALTH KZN

**GUM BOOTS — BLACK**  
**MALIE AND FEMALE GUMBOOTS**

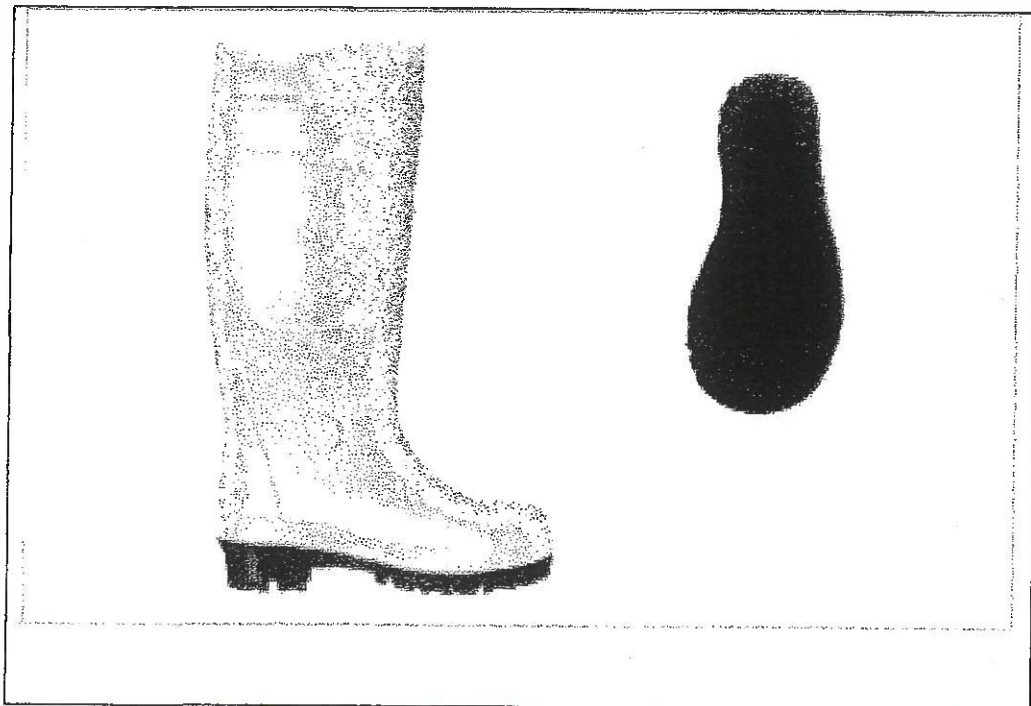

STYLE:



## DECLARATION CERTIFICATE FOR LOCAL PRODUCTION AND CONTENT FOR DESIGNATED SECTORS

This Standard Bidding Document (SBD) must form part of all bids invited. It contains general information and serves as a declaration form for local content (local production and local content are used interchangeably).

Before completing this declaration, bidders must study the General Conditions, Definitions, Directives applicable in respect of Local Content as prescribed in the Preferential Procurement Regulations, 2017, the South African Bureau of Standards (SABS) approved technical specification number SATS 1286:2011 (Edition 1) and the Guidance on the Calculation of Local Content together with the Local Content Declaration Templates [Annex C (Local Content Declaration: Summary Schedule), D (Imported Content Declaration: Supporting Schedule to Annex C) and E (Local Content Declaration: Supporting Schedule to Annex C)].

### 1. General Conditions

- 1.1. Preferential Procurement Regulations, 2017 (Regulation 8) make provision for the promotion of local production and content.
- 1.2. Regulation 8.(2) prescribes that in the case of designated sectors, organs of state must advertise such tenders with the specific bidding condition that only locally produced or manufactured goods, with a stipulated minimum threshold for local production and content will be considered.
- 1.3. Where necessary, for tenders referred to in paragraph 1.2 above, a two stage bidding process may be followed, where the first stage involves a minimum threshold for local production and content and the second stage price and B-BBEE.
- 1.4. A person awarded a contract in relation to a designated sector, may not sub-contract in such a manner that the local production and content of the overall value of the contract is reduced to below the stipulated minimum threshold.
- 1.5. The local content (LC) expressed as a percentage of the bid price must be calculated in accordance with the SABS approved technical specification number SATS 1286: 2011 as follows:

$$LC = [1 - x / y] * 100$$

Where

x is the imported content in Rand

y is the bid price in Rand excluding value added tax (VAT)

Prices referred to in the determination of x must be converted to Rand (ZAR) by using the exchange rate published by South African Reserve Bank (SARB) on the date of advertisement of the bid as indicated in paragraph 3.1 below.

**The SABS approved technical specification number SATS 1286:2011 is accessible on [http://www.thedti.gov.za/industrial\\_development/ip.jsp](http://www.thedti.gov.za/industrial_development/ip.jsp) at no cost.**

NB

- 1 The obligation to complete, duly sign and submit this declaration cannot be transferred to an external authorized representative, auditor or any other third party acting on behalf of the bidder.
- 2 Guidance on the Calculation of Local Content together with Local Content Declaration Templates (Annex C, D and E) is accessible on [http://www.thedli.gov.za/industrial\\_development/ip.jsp](http://www.thedli.gov.za/industrial_development/ip.jsp). Bidders should first complete Declaration D. After completing Declaration D, bidders should complete Declaration E and then consolidate the information on Declaration C. **Declaration C should be submitted with the bid documentation at the closing date and time of the bid in order to substantiate the declaration made in paragraph (c) below.** Declarations D and E should be kept by the bidders for verification purposes for a period of at least 5 years. The successful bidder is required to continuously update Declarations C, D and E with the actual values for the duration of the contract.

I, the undersigned, ..... (full names).  
do hereby declare, in my capacity as .....  
of ..... (name of bidder  
entity), the following:

- (a) The facts contained herein are within my own personal knowledge.
- (b) I have satisfied myself that:
  - (i) the goods/services/works to be delivered in terms of the above-specified bid comply with the minimum local content requirements as specified in the bid, and as measured in terms of SATS 1286:2011; and
- (c) The local content percentage (%) indicated below has been calculated using the formula given in clause 3 of SATS 1286:2011, the rates of exchange indicated in paragraph 3.1 above and the information contained in Declaration D and E which has been consolidated in Declaration C:

Bid price, excluding VAT (y)	R
Imported content (x), as calculated in terms of SATS 1286:2011	R
Stipulated minimum threshold for local content (paragraph 3 above)	
Local content %, as calculated in terms of SATS 1286:2011	

**If the bid is for more than one product, the local content percentages for each product contained in Declaration C shall be used instead of the table above.**

**The local content percentages for each product has been calculated using the formula given in clause 3 of SATS 1286:2011, the rates of exchange indicated in paragraph 3.1 above and the information contained in Declaration D and E.**

- (d) I accept that the Procurement Authority / Institution has the right to request that the local content be verified in terms of the requirements of SATS 1286:2011.
- (e) I understand that the awarding of the bid is dependent on the accuracy of the information furnished in this application. I also understand that the submission of incorrect data, or data that are not verifiable as described in SATS 1286:2011, may result in the Procurement Authority / Institution imposing any or all of the remedies as provided for in Regulation 14 of the Preferential Procurement Regulations, 2017

promulgated under the Preferential Policy Framework Act (PPPFA), 2000 (Act No. 5 of 2000).

**SIGNATURE:** \_\_\_\_\_

**WITNESS No. 1** \_\_\_\_\_

**DATE:** \_\_\_\_\_

**WITNESS No. 2** \_\_\_\_\_

**DATE:** \_\_\_\_\_

1.6. A bid may be disqualified if this Declaration Certificate and the Annex C (Local Content Declaration: Summary Schedule) are not submitted as part of the bid documentation;

2. The stipulated minimum threshold(s) for local production and content (refer to Annex A of SATS 1286:2011) for this bid is/are as follows:

<u>Description of services, works or goods</u>	<u>Stipulated minimum threshold</u>
<u>Uniform</u>	<u>100</u> %
_____	_____ %
_____	_____ %

3. Does any portion of the goods or services offered have any imported content?

(Tick applicable box)

YES	<input type="checkbox"/>	NO	<input checked="" type="checkbox"/>
-----	--------------------------	----	-------------------------------------

3.1 If yes, the rate(s) of exchange to be used in this bid to calculate the local content as prescribed in paragraph 1.5 of the general conditions must be the rate(s) published by SARB for the specific currency on the date of advertisement of the bid.

The relevant rates of exchange information is accessible on [www.resbank.co.za](http://www.resbank.co.za)

Indicate the rate(s) of exchange against the appropriate currency in the table below (refer to Annex A of SATS 1286:2011):

<b>Currency</b>	<b>Rates of exchange</b>
US Dollar	
Pound Sterling	
Euro	
Yen	
Other	

NB: Bidders must submit proof of the SARB rate (s) of exchange used.

4. Where, after the award of a bid, challenges are experienced in meeting the stipulated minimum threshold for local content the dti must be informed accordingly in order for the dti to verify and in consultation with the AO/AA provide directives in this regard.

**LOCAL CONTENT DECLARATION**  
**(REFER TO ANNEX B OF SATS 1286:2011)**

**LOCAL CONTENT DECLARATION BY CHIEF FINANCIAL OFFICER OR OTHER LEGALLY RESPONSIBLE PERSON NOMINATED IN WRITING BY THE CHIEF EXECUTIVE OR SENIOR MEMBER/PERSON WITH MANAGEMENT RESPONSIBILITY (CLOSE CORPORATION, PARTNERSHIP OR INDIVIDUAL)**

**IN RESPECT OF BID NO.** .....

**ISSUED BY:** (Procurement Authority / Name of Institution):  
.....





Annex D

SATS 12/16 2.3

Imported Content Declaration - Supporting Schedule to Annex C

(D1) Tender No. \_\_\_\_\_  
 (D2) Tender description: \_\_\_\_\_  
 (D3) Designated Products: \_\_\_\_\_  
 (D4) Tender Authority: \_\_\_\_\_  
 (D5) Tendering Entity name: \_\_\_\_\_  
 (D6) Tender Exchange Rate: \_\_\_\_\_

Note: VAT to be excluded from all calculations

EU R 9.00 GBP R 12.00

A. Exempted imported content

Tender item no's	Description of imported content	Local supplier	Overseas Supplier	Calculation of imported content						Summary	
				Foreign currency value as per Commercial Invoice	Tender Exchange Rate	Local value of imports	Freight costs to port of entry	All locally incurred landing costs & duties	Total landed cost excl VAT	Tender Qty	Exempted value
(D7)	(D8)	(D9)	(D10)	(D11)	(D12)	(D13)	(D14)	(D15)	(D16)	(D17)	(D18)
(D19) Total exempt imported value											

B. Imported directly by the Tenderer

Tender item no's	Description of imported content	Unit of measure	Overseas Supplier	Calculation of imported content						Summary	
				Foreign currency value as per Commercial Invoice	Tender Rate of Exchange	Local value of imports	Freight costs to port of entry	All locally incurred landing costs & duties	Total landed cost excl VAT	Tender Qty	Total imported value
(D20)	(D21)	(D22)	(D23)	(D24)	(D25)	(D26)	(D27)	(D28)	(D29)	(D30)	(D31)
(D32) Total imported value by tenderer											

C. Imported by a 3rd party and supplied to the Tenderer

Description of imported content	Unit of measure	Local supplier	Overseas Supplier	Calculation of imported content						Summary	
				Foreign currency value as per Commercial Invoice	Tender Rate of Exchange	Local value of imports	Freight costs to port of entry	All locally incurred landing costs & duties	Total landed cost excl VAT	Quantity imported	Total imported value
(D33)	(D34)	(D35)	(D36)	(D37)	(D38)	(D39)	(D40)	(D41)	(D42)	(D43)	(D44)
(D45) Total imported value by 3rd party											

D. Other foreign currency payments

Type of payment	Local supplier making the payment	Overseas beneficiary	Calculation of foreign currency payments	
			Foreign currency value paid	Tender Rate of Exchange
(D46)	(D47)	(D48)	(D49)	(D50)

(D51) Total of foreign currency payments declared by tenderer and/or 3rd party

(D52) Total of imported content & foreign currency payments - (D32), (D45) & (D51) above

Signature of tenderer from Annex B

Date: \_\_\_\_\_

This total must correspond to Annex C (D10)

## Annex E

### Local Content Declaration - Supporting Schedule to Annex C

(E1)	Tender No.	<input style="width: 95%;" type="text"/>
(E2)	Tender description:	<input style="width: 95%;" type="text"/>
(E3)	Designated products:	<input style="width: 95%;" type="text"/>
(E4)	Tender Authority:	<input style="width: 95%;" type="text"/>
(E5)	Tendering Entity name:	<input style="width: 95%;" type="text"/>

Note: VAT to be excluded from all calculations

Local Products (Goods, Services and Works)	Description of items purchased	Local suppliers	Value
	(E6)	(E7)	(E8)
<b>(E9) Total local products (Goods, Services and Works)</b>			R 0

(E10)	<b>Manpower costs</b> (Tenderer's manpower cost)	<input style="width: 95%;" type="text"/> R 0
(E11)	<b>Factory overheads</b> (Rental, depreciation & amortisation, utility costs, consumables etc.)	<input style="width: 95%;" type="text"/> R 0
(E12)	<b>Administration overheads and mark-up</b> (Marketing, insurance, financing, interest etc.)	<input style="width: 95%;" type="text"/> R 0
<b>(E13) Total local content</b>		<input style="width: 95%;" type="text"/> R 0

**This total must correspond with Annex C - C24**

Signature of tenderer from Annex B

Date: \_\_\_\_\_