

SharePoint

Mthethwa Phindile ▾ ?

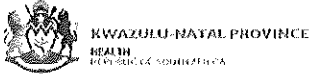

KZN Health Intranet

Search this site

[HOME](#) [CORPORATE INFORMATION](#) [COMPONENTS](#) [DIRECTORY](#) [DISTRICT OFFICES](#) [HEALTH FACILITIES](#)

KZN Health > [Components](#) > Supply Chain Management

AdvertQuote



Quotation Advert

Opening Date: 2021-11-24

Closing Date: 2021-12-02

Closing Time: 11:00

INSTITUTION DETAILS

Institution Name: Nkandla hospital

Province: KwaZulu-Natal

Department or Entity: Department of Health

Division or section: Central Supply Chain Management

Place where goods / services is required: Nkandla hospital

Date Submitted: 2021-11-24

ITEM CATEGORY AND DETAILS

Quotation Number: ZNQ:
ZNQ/NKA/152/21/22

Item Category: Goods

Item Description: 1. supply and deliver food macarator
2. supply and install conveyor belt
3. supply and deliver food dome covers and base - provide sample

Quantity (if supplies)

COMPULSORY BRIEFING SESSION / SITE VISIT

Select Type: Not Applicable

Date:

Time:

Venue:

QUOTES CAN BE COLLECTED FROM: internet

QUOTES SHOULD BE DELIVERED TO: Nkandla hospital tender box

ENQUIRIES REGARDING THE ADVERT MAY BE DIRECTED TO:

Name: Miss M.P. Letsoara

Email: phindile.mthethwa@kznhealth.gov.za

Contact Number: 035 833 5078

Finance Manager Name:

Miss P. Mthethwa

Finance Manager Signature:



No late quotes will be considered

STANDARD QUOTE DOCUMENTATION OVER R30 000.00

YOU ARE HEREBY INVITED TO QUOTE FOR REQUIREMENTS AT: NKANDLA HOSPITAL
DATE ADVERTISED: 24 NOVEMBER 2021 CLOSING DATE: 02 DECEMBER 2021 CLOSING TIME: 11:00
FACSIMILE NUMBER: 035 833 0054 E-MAIL ADDRESS: phindile.mthethwa@kznhealth.gov.za
PHYSICAL ADDRESS: 491 mbatha lane nkandla 3855

QUOTE NUMBER: ZNQ/NKA/152/21/22
DESCRIPTION: SUPPLY AND DELIVER FOOD DOME COVERS AND BASE
CONTRACT PERIOD: ONCE OFF (if applicable) VALIDITY PERIOD 60 Days SARS PIN:

CENTRAL SUPPLIER DATABASE REGISTRATION (CSD) NO. [Grid]

UNIQUE REGISTRATION REFERENCE [Grid]

DEPOSITED IN THE QUOTE BOX SITUATED AT (STREET ADDRESS)
[Grid]

Bidders should ensure that quotes are delivered timeously to the correct address. If the quote is late, it will not be accepted for consideration.

The quote box is open from 08:00 to 15:30.

QUOTATIONS MUST BE SUBMITTED ON THE OFFICIAL FORMS – (NOT TO BE RETYPED)

THIS QUOTE IS SUBJECT TO THE PREFERENTIAL PROCUREMENT POLICY FRAMEWORK ACT AND THE PREFERENTIAL PROCUREMENT REGULATIONS, 2011, THE GENERAL CONDITIONS OF CONTRACT (GCC) AND, IF APPLICABLE, ANY OTHER SPECIAL CONDITIONS OF CONTRACT.

THE FOLLOWING PARTICULARS MUST BE FURNISHED (FAILURE TO DO SO MAY RESULT IN YOUR QUOTE BEING DISQUALIFIED)

NAME OF BIDDER
POSTAL ADDRESS
STREET ADDRESS
TELEPHONE NUMBER CODE.....NUMBER..... FACSIMILE NUMBER CODE.....NUMBER.....
CELLPHONE NUMBER
E-MAIL ADDRESS
VAT REGISTRATION NUMBER (If VAT vendor)

HAS A B-BBEE STATUS LEVEL VERIFICATION CERTIFICATE BEEN SUBMITTED? (SBD 6.1) YES NO
[A B-BBEE STATUS LEVEL VERIFICATION CERTIFICATE/SWORN AFFIDAVIT (FOR EMEs& QSEs) MUST BE SUBMITTED TO QUALIFY FOR PREFERENCE POINTS FOR B-BBEE]

DESCRIPTION: SUPPLY AND DELIVER FOOD DOME COVERS AND BASE

SIGNATURE OF BIDDER DATE.....
 [By signing this document, I hereby agree to all terms and conditions]

CAPACITY UNDER WHICH THIS QUOTE IS SIGNED.....

Item No	Quantity	Description	Brand & model	Country of manufacture	Price	
					R	c
		SUPPLY, INSTALL AND PROVIDE TRAINING				
1	01	FOOD MACARATOR				
2.	01	INDUSTRIAL CONVEYER BELT TYPE MICROWAVE OVEN 220V				
		SUPPLY AND DELIVER				
3.	100	FOOD DOME COVERS & BASE				
		<i>Provide Sample</i>				
		SPECIFICATION ATTACHED				
VALUE ADDED TAX @ 15% (Only if VAT Vendor)						
TOTAL QUOTATION PRICE (VALIDITY PERIOD 60 Days)						

Does This Offer Comply With The Specification?	Does The Article Conform To The S.A.N.S. / S.A.B.S. Specification?
Is The Price Firm?	State Delivery Period, e.g., <i>1day, 1week</i>

Enquiries regarding the <u>quote</u> may be directed to: Contact Person: <u>M.P. LETSOARA</u> Tel: <u>035 833 5078</u> E-Mail Address: <u>phindiile.mthethwa@kznhealth.gov.za</u>	Enquiries regarding <u>technical information</u> may be directed to: Contact Person: <u>NOTHANDO NGEMA</u> Tel: <u>035 833 5010</u>
---	--

DECLARATION OF INTEREST

1. Any legal person, including persons employed by the state¹, or persons having a kinship with persons employed by the state, including a blood relationship, may make an offer or offers in terms of this invitation to quote (includes a price quotation, advertised competitive quote, limited quote or proposal). In view of possible allegations of favouritism, should the resulting quote, or part thereof, be awarded to persons employed by the state or to persons connected with or related to them, it is required that the bidder or his/her authorised representative declare his/her position in relation to the evaluating/adjudicating authority where-
 - the bidder is employed by the state; and/or
 - the legal person on whose behalf the bidding document is signed, has a relationship with persons/a person who are/is involved in the evaluation and or adjudication of the quote(s), or where it is known that such a relationship exists between the person or persons for or on whose behalf the declarant acts and persons who are involved with the evaluation and or adjudication of the quote.
2. In order to give effect to the above, the following questionnaire must be completed and submitted with the quote.

- 2.1. Full Name of bidder/representative.....
- 2.2. Identity Number:
- 2.3. Position occupied in the Company (director, trustee, shareholder?):
- 2.4. Company Registration Number:
- 2.5. Tax Reference Number:
- 2.6. VAT Registration Number:
- 2.7. The names of all directors / trustees / shareholders / members, their individual identity numbers, tax reference numbers and, if applicable, employee / persal numbers must be indicated in paragraph 3 below. [TICK APPLICABLE]
- 2.8. Are you or any person connected with the bidder presently employed by the state? YES NO
- 2.8.1. If so, furnish the following particulars:
 - Name of person / director / trustee / shareholder/ member:
 - Name of state institution at which you or the person connected to the bidder is employed:.....
 - Position occupied in the state institution:Any other particulars:.....
- 2.8.2. If you are presently employed by the state, did you obtain the appropriate authority to undertake remunerative work outside employment in the public sector? YES NO
- 2.8.2.1. If yes, did you attach proof of such authority to the quote document?
- 2.8.2.2. If no, furnish reasons for non-submission of such proof:
- (Note: Failure to submit proof of such authority, where applicable, may result in the disqualification of the quote.)
- 2.9. Did you or your spouse, or any of the company's directors / trustees / shareholders / members or their spouses conduct business with the state in the previous twelve months? YES NO
- 2.9.1. If so, furnish particulars:.....
- 2.10. Do you, or any person connected with the bidder, have any relationship (family, friend, other) with a person employed by the state and who may be involved with the evaluation and or adjudication of this quote? YES NO
- 2.10.1. If so, furnish particulars:.....
- 2.11. Are you, or any person connected with the bidder, aware of any relationship (family, friend, other) between any other bidder and any person employed by the state who may be involved with the evaluation and or adjudication of this quote? YES NO
- 2.11.1. If so, furnish particulars:.....
- 2.12. Do you or any of the directors / trustees / shareholders / members of the company have any interest in any other related companies whether or not they are bidding for this contract? YES NO
- 2.12.1. If so, furnish particulars:.....

3. Full details of directors / trustees / members / shareholders.

NB: The Department Of Health will validate details of directors / trustees / members / shareholders on CSD. It is the suppliers' responsibility to ensure that their details are up-to-date and verified on CSD. If the Department cannot validate the information on CSD, the quote will not be considered and passed over as non-compliant according to National Treasury Instruction Note 4 (a) 2016/17.

4 DECLARATION

I, THE UNDERSIGNED (NAME).....CERTIFY THAT THE INFORMATION FURNISHED IN PARAGRAPHS 2.

I ACCEPT THAT THE STATE MAY REJECT THE QUOTE OR ACT AGAINST ME SHOULD THIS DECLARATION PROVE TO BE FALSE.

.....
Name of bidder	Signature	Position	Date

"State" means –

- | | |
|---|---|
| a) any national or provincial department, national or provincial public entity or constitutional institution within the meaning of the Public Finance Management Act, 1999 (Act No. 1 of 1999); | c) provincial legislature; |
| b) any municipality or municipal entity; | d) national Assembly or the national Council of provinces; or |
| | e) Parliament. |

"Shareholder" means a person who owns shares in the company and is actively involved in the management of the enterprise or business and exercises control over the enterprise.

SPECIAL CONTRACT CONDITIONS OF QUOTATIONS

1. AMENDMENT OF CONTRACT

- 1.1. Any amendment to or renunciation of the provisions of the contract shall at all times be done in writing and shall be signed by both parties.

2. CHANGE OF ADDRESS

- 2.1. Bidders must advise the Department of Health (institution where the offer was submitted) should their address (*domicilium citandi et executandi*) details change from the time of bidding to the expiry of the contract.

3. GENERAL CONDITIONS ATTACHED TO THIS QUOTATION

- 3.1. The Department is under no obligation to accept the lowest or any quote.
- 3.2. The Department reserves the right to communicate in writing with vendors in cases where information is incomplete or where there are obscurities regarding technical aspects of the offer, to obtain confirmation of prices or preference claims in cases where it is evident that a typing, written, transfer or unit error has been made, to investigate the vendor's standing and ability to complete the supply/service satisfactorily.
- 3.3. **ALL DECISIONS TAKEN BY THE DEPARTMENT ARE FINAL, INCLUDING THE AWARD OF THIS QUOTATION.**
- 3.4. The price quoted must include VAT (if VAT vendor). However, it must be noted that the Department reserves the right to evaluate all quotations excluding VAT as some bidders may not be VAT vendors.
- 3.5. The bidder must ensure the correctness & validity of the quotation:
- (i) *that the price(s), rate(s) & preference quoted cover all for the work/item (s) & accept that any mistakes regarding the price (s) & calculations will be at the bidder's risk*
 - (ii) *it is the responsibility of the bidder to confirm receipt of their quotation and to keep proof thereof.*
- 3.6. The bidder must accept full responsibility for the proper execution & fulfilment of all obligations conditions devolving on under this agreement, as the Principal (s) liable for the due fulfilment of this contract.
- 3.7. This quotation will be evaluated based on the 80/20 points system, specification, correctness of information and/or functionality criteria. All required documentation must be completed in full and submitted.
- 3.8. Offers must comply strictly with the specification.
- 3.9. Only offers that meet or are greater than the specification will be considered.
- 3.10. Late offers will not be considered.
- 3.11. Expired product/s will not be accepted. All products supplied must be valid for a minimum period of six months.
- 3.12. Used/ second-hand products will not be accepted.
- 3.13. A bidder not registered on the Central Suppliers Database or whose verification has failed will not be considered.
- 3.14. All delivery costs must be included in the quoted price for delivery at the prescribed destination.
- 3.15. Only firm prices will be accepted. Such prices must remain firm for the contract period. Non-firm prices (including rates of exchange variations) will not be considered.
- 3.16. In cases where different delivery points influence the pricing, a separate pricing schedule must be submitted for each delivery point.
- 3.17. In the event of a bidder having multiple quotes, only the cheapest according to specification will be considered.
- 3.18. Verification will be conducted to identify if bidders have multiple companies and are cover-quoting for this bid.
- 3.19. In such instances, the Department reserves the right to immediately disqualify such bidders as cover-quoting is an offence that represents both corruption and acquisition fraud.

4. SPECIAL INSTRUCTIONS AND NOTICES TO BIDDERS REGARDING THE COMPLETION OF THIS QUOTATION.

- 4.1. Unless inconsistent with or expressly indicated otherwise by the context, the singular shall include the plural and vice versa and with words importing the masculine gender shall include the feminine and the neuter.
- 4.2. Under no circumstances whatsoever may the quotation/bid forms be retyped or redrafted. Photocopies of the original bid documentation may be used, but an original signature must appear on such photocopies.
- 4.3. The bidder is advised to check the number of pages and to satisfy himself that none are missing or duplicated.
- 4.4. Quotations submitted must be complete in all respects. However, where it is identified that information in a bidder's response is incomplete in any respect, the said supplier meets all specification requirements and is lowest to quote, the Department reserves the right to request the bidder to complete/submit such information.
- 4.5. Any alteration made by the bidder must be initialled; failure to do so may render the response invalid.
- 4.6. Use of correcting fluid is prohibited and may render the response invalid.
- 4.7. Quotations will be opened in public as soon as practicable after the closing time of quotation.
- 4.8. Where practical, prices are made public at the time of opening quotations.
- 4.9. If it is desired to make more than one offer against any individual item, such offers should be given on a photocopy of the page in question. Clear indication thereof must be stated on the schedules attached.
- 4.10. The Department is under no obligation to pay suppliers in part for work done if the supplier can no longer for fulfil their obligation.

5. SPECIAL INSTRUCTIONS REGARDING HAND DELIVERED QUOTATIONS

- 5.1. Quotation shall be lodged at the address indicated not later than the closing time specified for their receipt, and in accordance with the directives in the quotation documents.
- 5.2. Each quotation shall be addressed in accordance with the directives in the quotation documents and shall be lodged in a separate sealed envelope, with the name and address of the bidder, the quotation number and closing date indicated on the envelope. The envelope shall not contain documents relating to any quotation other than that shown on the envelope. If this provision is not complied with, such quotations/bids may be rejected as being invalid.
- 5.3. All quotations received in sealed envelopes with the relevant quotation numbers on the envelopes are kept unopened in safe custody until the closing time of the quotation/bids. Where, however, a quotation is received open, it shall be sealed. If it is received without a quotation/bid number on the envelope, it shall be opened, the quotation number ascertained, the envelope sealed and the quotation number written on the envelope.
- 5.4. A specific box is provided for the receipt of quotations, and no quotation found in any other box or elsewhere subsequent to the closing date and time of quotation will be considered.
- 5.5. No quotation/bid sent through the post will be considered if it is received after the closing date and time stipulated in the quotation documentation, and proof of posting will not be accepted as proof of delivery.
- 5.6. Quotation documents must not be included in packages containing samples. Such quotations may be rejected as being invalid.

6. SAMPLES

- 6.1. In the case of the quote document stipulating that samples are required, the supplier will be informed in due course when samples should be provided to the institution. (This decreases the time of safety and storage risk that may be incurred by the respective institution). The bidders sample will be retained if such bidder wins the contract.
 - (i) If a company/s who has not won the quote requires their samples, they must advise the institution in writing of such.
 - (ii) If samples are not collected within three months of close of quote the institution reserves the right to dispose of them at their discretion.
- 6.2. **Samples must be made available when requested in writing or if stipulated on the document.**
 - (i) If a Bidder fails to provide a sample of their product on offer for scrutiny against the set specification when requested, their offer will be rejected. All testing will be for the account of the bidder.

7. COMPULSORY SITE INSPECTION / BRIEFING SESSION

- 7.1. Bidders who fail to attend the compulsory meeting will be disqualified from the evaluation process.
 - (i) The institution has determined that a compulsory site meeting N/A take place
 - (ii) Date: ____/____/____ Time: ____:____ Place: _____

Institution Stamp:	Institution Site Inspection / briefing session Official Full Name: Signature: Date:
--------------------	--

8. STATEMENT OF SUPPLIES AND SERVICES

- 8.1. The contractor shall, when requested to do so, furnish particulars of supplies delivered or services executed. If he/she fails to do so, the Department may, without prejudice to any other rights which it may have, institute inquiries at the expense of the contractor to obtain the required particulars.

9. SUBMISSION AND COMPLETION OF SBD 6.1

- 9.1. Should a bidder wish to qualify for preference points they must complete a SBD 6.1 document. Failure by a bidder to provide all relevant information required, will result in such a bidder not being considered for preference point's allocation. The preferences applicable on the closing date will be utilized. Any changes after the closing date will not be considered for that particular quote.

10. TAX COMPLIANCE REQUIREMENTS

- 10.1. In the event that the tax compliance status has failed on CSD, **it is the suppliers' responsibility to provide a SARS pin in order for the institution to validate the tax compliance status of the supplier.**
- 10.2. In the event that the institution cannot validate the suppliers' tax clearance on SARS as well as the Central Suppliers Database, **the quote will not be considered and passed over as non-compliant according to National Treasury Instruction Note 4 (a) 2016/17.**

11. TAX INVOICE

11.1. A tax invoice shall be in the currency of the Republic of South Africa and shall contain the following particulars:

- | | |
|--|--|
| (i) the name, address and registration number of the supplier; | (iv) a description and quantity or volume of the goods or services supplied; |
| (ii) the name and address of the recipient; | (v) the official department order number issued to the supplier; |
| (iii) an individual serialized number and the date upon which the tax invoice is issued; | (vi) the value of the supply, the amount of tax charged; |
| | (vii) the words tax invoice in a prominent place. |

12. PATENT RIGHTS

The supplier shall indemnify the **KZN Department of Health** (hereafter known as the purchaser) against all third-party claims of infringement of patent, trademark, or industrial design rights arising from use of the goods or any part thereof by the purchaser.

13. PENALTIES

- 13.1. If at any time during the contract period, the service provider is unable to perform in a timely manner, the service provider must notify the institution in writing/email of the cause of and the duration of the delay. Upon receipt of the notification, the institution should evaluate the circumstances and, if deemed necessary, the institution may extend the service provider's time for performance.
- 13.2. In the event of delayed performance that extends beyond the delivery period, the institution is entitled to purchase commodities of a similar quantity and quality as a substitution for the outstanding commodities, without terminating the contract, as well as return commodities delivered at a later stage at the service provider's expense.
- 13.3. Alternatively, the institution may elect to terminate the contract and procure the necessary commodities in order to complete the contract. In the event that the contract is terminated the institution may claim damages from the service provider in the form of a penalty. The service provider's performance should be captured on the service provider database in order to determine whether or not the service provider should be awarded any contracts in the future.
- 13.4. If the supplier fails to deliver any or all of the goods or to perform the services within the period(s) specified in the contract, the purchaser shall, without prejudice to its other remedies under the contract, deduct from the contract price, as a penalty, a sum calculated on the delivered price of the delayed goods or unperformed services using the current prime interest rate calculated for each day of the delay until actual delivery or performance.

14. TERMINATION FOR DEFAULT

- 14.1. The purchaser, without prejudice to any other remedy for breach of contract, by written notice of default sent to the supplier, may terminate this contract in whole or in part:
- (i) if the supplier fails to deliver any or all of the goods within the period(s) specified in the contract,
 - (ii) if the supplier fails to perform any other obligation(s) under the contract; or
 - (iii) if the supplier, in the judgment of the purchaser, has engaged in corrupt or fraudulent practices in competing for or in executing the contract.
- 14.2. In the event the purchaser terminates the contract in whole or in part, the purchaser may procure, upon such terms and in such manner as it deems appropriate, goods, works or services similar to those undelivered, and the supplier shall be liable to the purchaser for any excess costs for such similar goods, works or services.
- 14.3. Where the purchaser terminates the contract in whole or in part, the purchaser may decide to impose a restriction penalty on the supplier by prohibiting such supplier from doing business with the public sector for a period not exceeding 10 years.

15. FAILURE TO COMPLY WITH ABOVE WILL RESULT IN YOUR QUOTE BEING PASSED OVER.

PREFERENCE POINTS CLAIM FORM IN TERMS OF THE PREFERENTIAL PROCUREMENT REGULATIONS 2017

This preference form must form part of all quotes invited. It contains general information and serves as a claim form for preference points for Broad-Based Black Economic Empowerment (B-BBEE) Status Level of Contribution

NB: BEFORE COMPLETING THIS FORM, BIDDERS MUST STUDY THE GENERAL CONDITIONS, DEFINITIONS AND DIRECTIVES APPLICABLE IN RESPECT OF B-BBEE, AS PRESCRIBED IN THE PREFERENTIAL PROCUREMENT REGULATIONS, 2017.

1. GENERAL CONDITIONS

1.1 The following preference point systems are applicable to all quotes:

- the 80/20 system for requirements with a Rand value of up to R50 000 000 (all applicable taxes included); and

1.2 The value of this quote is estimated to not exceed R50 000 000 (all applicable taxes included) and therefore the 80/20 preference point system shall be applicable.

1.3 Points for this quote shall be awarded for:

- (a) Price; and
- (b) B-BBEE Status Level of Contributor.

1.4 The maximum points for this quote is allocated as follows:

	POINTS
PRICE	80
B-BBEE STATUS LEVEL OF CONTRIBUTOR	20
Total points for Price and B-BBEE must not exceed	100

1.5 Failure on the part of a bidder to submit proof of B-BBEE Status level of contributor together with the quote, will be interpreted to mean that preference points for B-BBEE status level of contribution are not claimed.

1.6 The purchaser reserves the right to require of a bidder, either before a quote is adjudicated or at any time subsequently, to substantiate any claim in regard to preferences, in any manner required by the purchaser.

2. DEFINITIONS

- (a) **"B-BBEE"** means broad-based black economic empowerment as defined in section 1 of the Broad-Based Black Economic Empowerment Act;
- (b) **"B-BBEE status level of contributor"** means the B-BBEE status of an entity in terms of a code of good practice on black economic empowerment, issued in terms of section 9(1) of the Broad-Based Black Economic Empowerment Act;
- (c) **"bid"** means a written offer in a prescribed or stipulated form in response to an invitation by an organ of state for the provision of goods or services, through price quotations, advertised competitive bidding processes or proposals;
- (d) **"Broad-Based Black Economic Empowerment Act"** means the Broad-Based Black Economic Empowerment Act, 2003 (Act No. 53 of 2003);
- (e) **"EME"** means an Exempted Micro Enterprise in terms of a code of good practice on black economic empowerment issued in terms of section 9 (1) of the Broad-Based Black Economic Empowerment Act;
- (f) **"functionality"** means the ability of a tenderer to provide goods or services in accordance with specifications as set out in the tender documents.
- (g) **"prices"** includes all applicable taxes less all unconditional discounts;
- (h) **"proof of B-BBEE status level of contributor"** means:
 - 1) B-BBEE Status level certificate issued by an authorized body or person;
 - 2) A sworn affidavit as prescribed by the B-BBEE Codes of Good Practice;
 - 3) Any other requirement prescribed in terms of the B-BBEE Act;
- (i) **"QSE"** means a qualifying small business enterprise in terms of a code of good practice on black economic empowerment issued in terms of section 9 (1) of the Broad-Based Black Economic Empowerment Act;
- (j) **"rand value"** means the total estimated value of a contract in Rand, calculated at the time of bid invitation, and includes all applicable taxes;

3. POINTS AWARDED FOR PRICE

3.1 THE 80/20 PREFERENCE POINT SYSTEMS

A maximum of 80 points is allocated for price on the following basis:

$$Ps = 80 \left(1 - \frac{Pt - P \text{ min}}{P \text{ min}} \right) \text{ Where}$$

- Ps = Points scored for price of bid under consideration
- Pt = Price of bid under consideration
- Pmin = price of lowest acceptable bid

4. POINTS AWARDED FOR B-BBEE STATUS LEVEL OF CONTRIBUTOR

4.1 In terms of Regulation 6 (2) and 7 (2) of the Preferential Procurement Regulations, preference points must be awarded to a bidder for attaining the B-BBEE status level of contribution in accordance with the table below:

B-BBEE Status Level of Contributor	Number of points (80/20 system)
1	20
2	18
3	14
4	12
5	8
6	6
7	4
8	2
Non-compliant contributor	0

5. BID DECLARATION

5.1 Bidders who claim points in respect of B-BBEE Status Level of Contribution must complete the following:

6. B-BBEE STATUS LEVEL OF CONTRIBUTOR CLAIMED IN TERMS OF PARAGRAPHS 1.4 AND 4.1

6.1 B-BBEE Status Level of Contributor: =(maximum of 20 points)

(Points claimed in respect of paragraph 7.1 must be in accordance with the table reflected in paragraph 4.1 and must be substantiated by relevant proof of B-BBEE status level of contributor.

7. SUB-CONTRACTING
(applicable box)

(Tick

YES		NO	
-----	--	----	--

7.1 Will any portion of the contract be sub-contracted?

7.1.1 If yes, indicate:

- i) What percentage of the contract will be subcontracted.....%
- ii) The name of the sub-contractor.....
- iii) The B-BBEE status level of the sub-contractor.....

8. Whether the sub-contractor is an EME or QSE

(Tick applicable box)

iv) Specify, by ticking the appropriate box, if subcontracting with an enterprise in terms of Preferential Procurement Regulations, 2017:

YES		NO	
-----	--	----	--

Designated Group: An EME or QSE which is at least 51% owned by:	EME √	QSE √
Black people		
Black people who are youth		
Black people who are women		
Black people with disabilities		
Black people living in rural or underdeveloped areas or townships		
Cooperative owned by black people		
Black people who are military veterans		
OR		
Any EME		

Any QSE		
---------	--	--

9. **DECLARATION WITH REGARD TO COMPANY/FIRM**

9.1 Name of company/firm:.....

9.2 VAT registration number:.....

9.3 Company registration number:.....

9.4 **TYPE OF COMPANY/ FIRM [TICK APPLICABLE BOX]**

- Partnership/Joint Venture / Consortium
- One person business/sole propriety
- Close corporation
- Company
- (Pty) Limited

9.5 **DESCRIBE PRINCIPAL BUSINESS ACTIVITIES**

.....

9.6 **COMPANY CLASSIFICATION [TICK APPLICABLE BOX]**

- Manufacturer
- Supplier
- Professional service provider
- Other service providers, e.g. transporter, etc.

9.7 Total number of years the company/firm has been in business:.....

9.8 I/we, the undersigned, who is / are duly authorised to do so on behalf of the company/firm, certify that the points claimed, based on the B-BBE status level of contributor indicated in paragraphs 1.4 and 6.1 of the foregoing certificate, qualifies the company/ firm for the preference(s) shown and I / we acknowledge that:

- i) The information furnished is true and correct;
- ii) The preference points claimed are in accordance with the General Conditions as indicated in paragraph 1 of this form;
- iii) In the event of a contract being awarded as a result of points claimed as shown in paragraphs 1.4 and 6.1, the contractor may be required to furnish documentary proof to the satisfaction of the purchaser that the claims are correct;
- iv) If the B-BBEE status level of contributor has been claimed or obtained on a fraudulent basis or any of the conditions of contract have not been fulfilled, the purchaser may, in addition to any other remedy it may have –
 - (a) disqualify the person from the bidding process;
 - (b) recover costs, losses or damages it has incurred or suffered as a result of that person's conduct;
 - (c) cancel the contract and claim any damages which it has suffered as a result of having to make less favourable arrangements due to such cancellation;
 - (d) recommend that the bidder or contractor, its shareholders and directors, or only the shareholders and directors who acted on a fraudulent basis, be restricted by the National Treasury from obtaining business from any organ of state for a period not exceeding 10 years, after the *audi alteram partem* (hear the other side) rule has been applied; and
 - (e) forward the matter for criminal prosecution.

<p>WITNESSES</p> <p>1.</p> <p>2.</p>

<p>..... SIGNATURE(S) OF BIDDERS(S)</p> <p>DATE:</p> <p>ADDRESS..... </p>
--



END-USER EVALUATION FORM

Quote Number: _____

Item Description: FOOD DOME AND COVERS

Company/ Supplier: _____

State Branding Name on product: _____

Department/Section: _____

Purpose of Item: PRESERVE HEAT AND SAFETY IN PATIENT FOOD

1. Has a sample been submitted? Yes / No

Give Reasons if No: _____

2. Does the product comply with the specification? Yes / No

List specifications as advertised	Comply Yes/No	Comment
1. Insulated Dome 8,17 cm		
2.		
3. 22,86 cm Ceramic Plate		
4.		
5. Maroon in colour		
6.		
7. Petter underliner holds 24,13 cm		
8.		
9.		
10.		

3. Does the product performance meet requirements as stipulated in the specification? Yes / No

Give Reasons if No: _____

4. Are evaluation criteria / special terms and conditions met as advertised?

List evaluation criteria / special terms and conditions as advertised (if applicable)	Comply Yes/No	Comment
1.		
2.		
3.		
4.		
5.		

5. Is the product recommended? Yes / No

Give Reasons if No: _____

6. Has the product been used before? Yes / No

If yes, was it found to be suitable: _____

Name of End-user	<u>N. NGEMA</u>	Name of SCM representative	
Designation/ Rank (in full)	<u>FOOD SERVICE MANAGER</u>	Designation/ Rank (in full)	
Signature		Signature	
Date		Date	

sinkmaster[®]

FOOD WASTE DISPOSERS



Designed in the United States!

Assembled in South Africa

**COMMERCIAL DISPOSER SYSTEMS...
WHEN QUALITY COUNTS**

sinkmaster®

COMMERCIAL

1 1/4 HP (.9 kW) Typical Application:

Medium volume with waste of softer menu, e.g. pizzeria, hamburger, 150 bed hospital

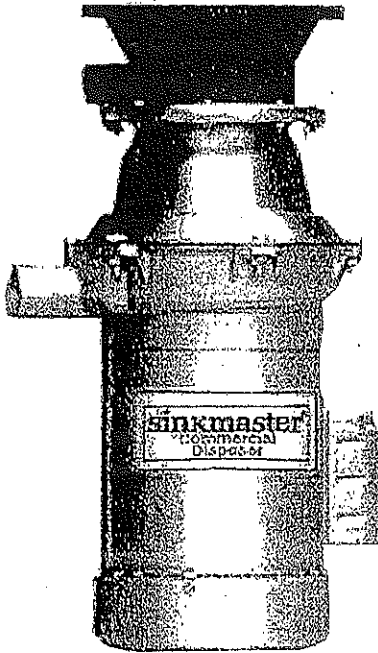

2 HP (1.5 kW) Typical Application:

Medium to large restaurants with heavy volume but only the food waste difficulty resulting from an average menu, eg. seafood restaurant, 250 bed hospital

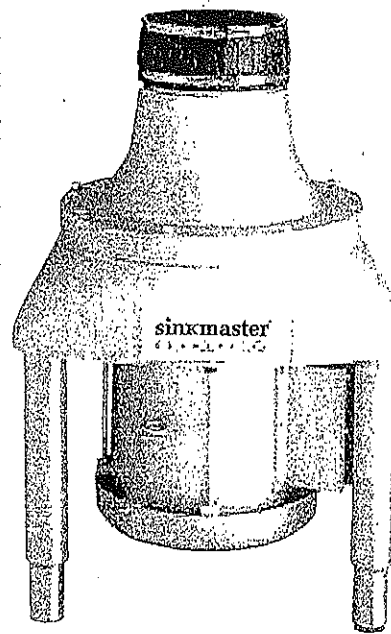
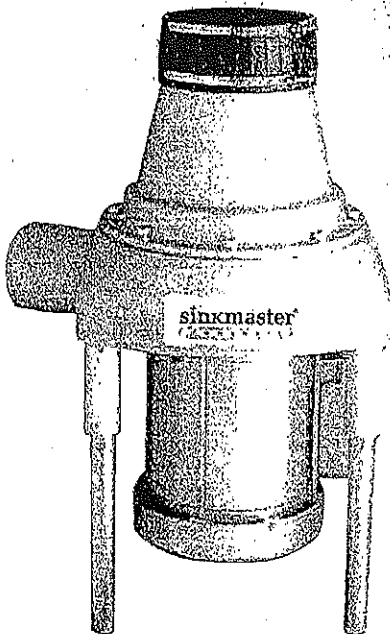
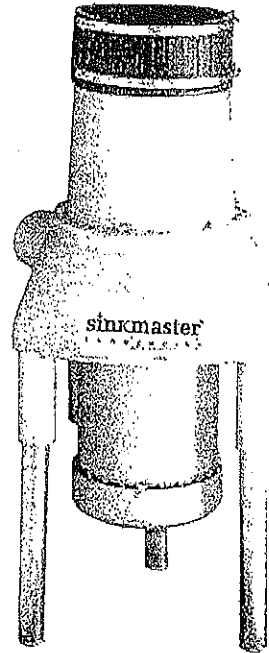

3 HP (2.2 kW) Typical Application:

Schools, larger hospitals, grill house and restaurants with some difficult waste and medium to heavy volume.

5 HP (4.0 kW) Typical Application:

High volume, mass feeding operation where peak loads are extreme and volume of difficult waste is continuous, e.g. conference centre, food processing plant.

SINKMASTER... DOES A BETTER JOB FOURTEEN WAYS!

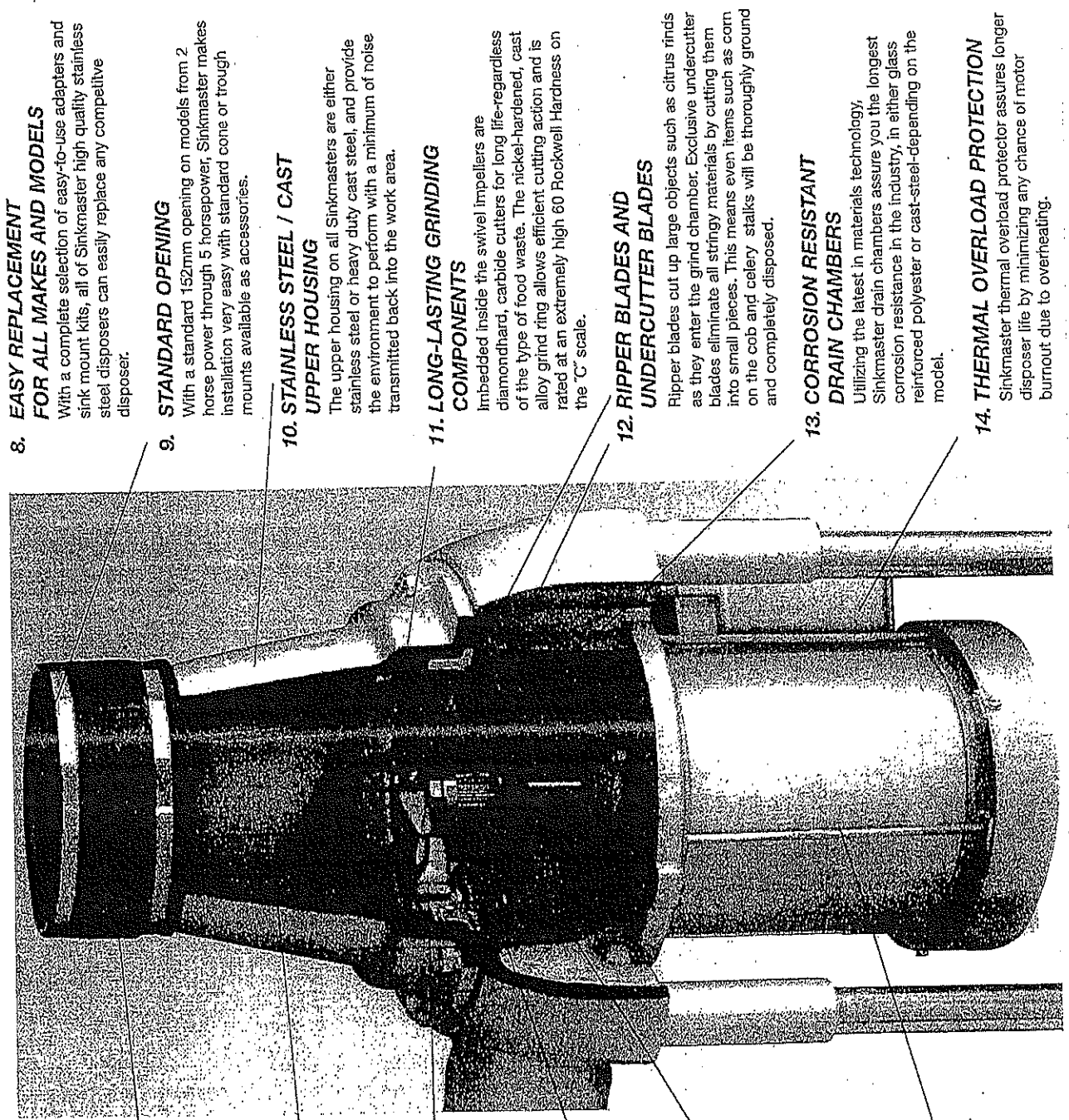

- 1. CORROSION RESISTANCE**
All of Sinkmaster commercial disposers are resistant to corrosion, utilizing the latest in materials technology and providing stainless steel components in the grind chamber—where it counts. Sinkmaster lasts longer.
- 2. HUSH CUSHION QUIETNESS**
All Sinkmaster Disposers are fastened to the sink with a "hush cushion" suspension. This unique Sinkmaster feature minimizes noise transmitted from the operating disposer up through the sink into the work area, allowing the disposer to perform many decibels more quietly than competitive models.
- 3. DIRECTIONAL DOWNFEED**
A Sinkmaster exclusive, the directional downfeed ridge assures complete drainage, eliminates odours, and actively provides a thorough interior cleansing of the entire disposer system.
- 4. SWIVEL IMPELLERS**
Sinkmaster was the originator of swivel impellers and the first to patent this unique feature which provides for anti-jamming. Because the impellers swivel, there is no need for a reversing motor. They move out of the way of an impending jam and then fall back into position. Diamond hard carbide inserts provide longer life on heavy duty units.
- 5. DYNAMICALLY BALANCED STAINLESS STEEL TURNABLE**
The heart of all our disposers and the assurance of superb performance, our dynamically balanced stainless steel turntable insures evenness of cutting and long motor life.
- 6. TRIPLE LIP PROTECTED SEALS**
Sinkmaster provides unsurpassed "state-of-the-art" triple lip seal protection reinforced by stainless steel springs to prevent any moisture from reaching the motor. In addition, all disposers are designed with a "slinger ring", to protect the seal from unwanted moisture and objects such as straws.
- 7. HEAVY DUTY CONTINUOUS-USE INDUCTION MOTORS**
Sinkmaster uses only industrial quality, continuous use induction motors that are permanently lubricated and thermally protected for long life and economical use.

8. EASY REPLACEMENT FOR ALL MAKES AND MODELS

With a complete selection of easy-to-use adapters and sink mount kits, all of Sinkmaster high quality stainless steel disposers can easily replace any competitive disposer.

9. STANDARD OPENING

With a standard 152mm opening on models from 2 horse power through 5 horsepower, Sinkmaster makes installation very easy with standard cone or trough mounts available as accessories.

10. STAINLESS STEEL / CAST UPPER HOUSING

The upper housing on all Sinkmasters are either stainless steel or heavy duty cast steel, and provide the environment to perform with a minimum of noise transmitted back into the work area.

11. LONG-LASTING GRINDING COMPONENTS

Imbedded inside the swivel impellers are diamondhard, carbide cutters for long life—regardless of the type of food waste. The nickel-hardened, cast alloy grind ring allows efficient cutting action and is rated at an extremely high 60 Rockwell Hardness on the "C" scale.

12. RIPPER BLADES AND UNDERCUTTER BLADES

Ripper blades cut up large objects such as citrus rinds as they enter the grind chamber. Exclusive undercutter blades eliminate all stringy materials by cutting them into small pieces. This means even items such as corn on the cob and celery stalks will be thoroughly ground and completely disposed.

13. CORROSION RESISTANT DRAIN CHAMBERS

Utilizing the latest in materials technology, Sinkmaster drain chambers assure you the longest corrosion resistance in the industry, in either glass reinforced polyester or cast-steel—depending on the model.

14. THERMAL OVERLOAD PROTECTION

Sinkmaster thermal overload protector assures longer disposer life by minimizing any chance of motor burnout due to overheating.

SINKMASTER ... PROVIDES A COMPLETE WATER SAVING SYSTEM, WITH QUALITY THAT LASTS!

Sinkmaster Commercial Disposers will replace any competitive disposer and can be installed into any type of sink or sink opening.

CONE ASSEMBLIES

The Cone assembly is for use in dump tables, or an all-purpose configuration, the cone available is in standard, 1 1/2"/380mm diameter. All groups include siphon breaker, solenoid valve, swift sprays, cutlery guard, scrap ring and on/off switch.

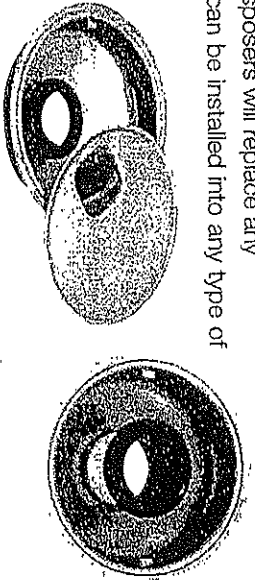

TROUGH ASSEMBLY

contain the 152mm or 203mm trough and a swift spray.

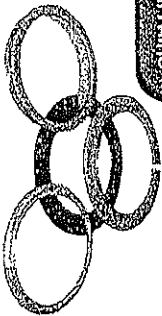

Sinkmaster commercial disposers are built to exacting standards that have been our trademark for almost 50 years. Because of this, our commercial disposers have one of the lowest levels of required service in the industry. Sinkmaster is quality you can depend upon - with fewer service problems.

Sinkmaster understands that more demanding applications require a stronger grind chamber design in addition to a more powerful motor.

IDEAL INSTALLATION

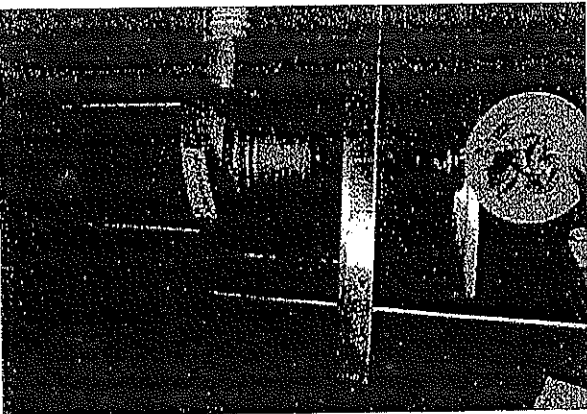

N.B. The Sinkmaster must bypass the grease trap - min. water pressure required - 3 bar

Most other brands use only one grind chamber for all models and then "bolt on" larger motors for better units.

This superb grind chamber design means Sinkmaster disposers perform more quickly and efficiently with less noise, heat and water consumption. As a result, Sinkmaster disposers last longer. Quality you would expect from the standard of the industry... Sinkmaster.

SINKMASTER DISPOSERS: Environmentally and Socially Beneficial!

Reduce and Recycle Waste -

Disposers shred and pulp food waste material into small pieces that are then flushed down the drain. The shredding and pulping action releases water trapped inside the food material. Since water makes up to 85% of the bulk in most food waste, disposers actually reduce the volume of food. The tiny food particles are easily handled and digested by the biological action of the waste treatment plant, septic tank, and/or the environment.

Save Government and Taxpayer's Money -

Curbside collection is expensive and inefficient, further contributing to the current problems of landfill overflowing and pollution caused by incineration. By reducing the overall waste volume, disposers save money by: a) facilitating re-cycling of day waste and b) offering a partial and economic solution to the increasing worldwide problem of waste transportation and disposal. New S.A. Government legislation. Bill Gazette - No 29487 Jan 2007

Improve Sanitary and Health Conditions -

Reduction of street garbage collection reduces pollution. The elimination of breeding grounds for rodents, insects, and other pests improves sanitation. Both the kitchen and the neighbourhood enjoy improved health and sanitary conditions with lower health care costs.



SPECIFICATIONS

Model	HP/KW	Opening	Voltages & Phases	Drain Size	Height
750-3	1/4/1.55	6"/150mm	380/3	50mm	455mm minimum
1250-3	1 1/4/1.9	6"/152mm	380/3	50mm	470mm minimum
2000-3	2/1.5	6"/152mm	380/3	50mm	655mm minimum
3000-3	3/2.8	6"/152mm	380/3	70mm	655mm minimum
5000-3	5/3.8	6"/78"	380/3	110mm	667mm minimum
10000-3	10	8"/203mm	380/3	110mm	675mm minimum

The reliable appliance that makes life more convenient in a hygienic environment.

HEAD OFFICE: P.O. Box 3687, Cresta, Johannesburg, 2118
Tel: 011 476 4826
Fax: 011 476 8787
Cell: 083 235 2836
Email: sinkmaster@sentechna.com

DURBAN: Tel: 031 705 7742

PORT ELIZABETH: Tel: 041 368 2722

CAPE TOWN: Tel: 021 798 4777

AGENTS: KLERKSDORP, NELSPRUIT, GEORGE, KNYSNA, BLOEMFONTEIN



END-USER EVALUATION FORM

Quote Number: _____

Item Description: FOOD WASTE DISPOSAL

Company/ Supplier: _____

State Branding Name on product: _____

Department/Section: _____

Purpose of Item: REMOVAL OF FOOD WASTE FROM WARDS

1. Has a sample been submitted? Yes / ~~No~~

Give Reasons if No: _____

2. Does the product comply with the specification? Yes / No

List specifications as advertised	Comply Yes/No	Comment
1. MODEL "1250-3		
2. HP/KW 1 3/4 / 09		
3.		
4. OPENING 6" / 152mm		
5.		
6. VOLTAGES & PHASES 380/3		
7.		
8. DRAIN SIZE 50mm		
9.		
10. HEIGHT 470mm minimum		

3. Does the product performance meet requirements as stipulated in the specification? Yes / No

Give Reasons if No: _____

4. Are evaluation criteria / special terms and conditions met as advertised?

List evaluation criteria / special terms and conditions as advertised (if applicable)	Comply Yes/No	Comment
1.		
2.		
3.		
4.		
5.		

5. Is the product recommended? Yes / No

Give Reasons if No: _____

6. Has the product been used before? Yes / No

If yes, was it found to be suitable: _____

Name of End-user	N. NGEMA	Name of SCM representative	
Designation/ Rank (in full)	FSM FOOD SERVICE MANAGER	Designation/ Rank (in full)	
Signature		Signature	
Date		Date	

TEMPERATURE RETENTION SYSTEMS

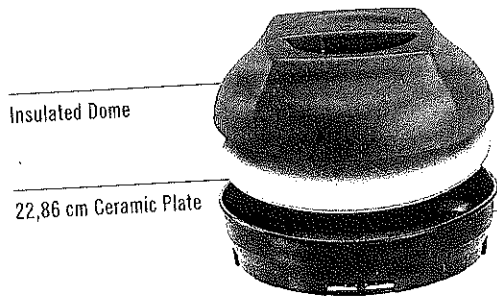

Camduction® Base

- Camduction Bases are durable and dishwasher safe.
- Resistant to chips, cracks and breaks.
- Revolutionary technology eliminates errors or issues with spikes in voltage.
- 2 year pro-rated warranty on Bases.
- Holds a 22,86 cm plate.

MDS09, MDSL09 and MDCDB09EU24V Colors: Meadow (457), Speckled Gray (480), Cranberry (487), Navy Blue (497), Black (110).

MDSPLT9 Color: White (148).
MDSPLT9 Sold in full cases only.

MDCDB09EU24V is covered by U.S. P D 630, 8975 S. and 8,263,906 B2.

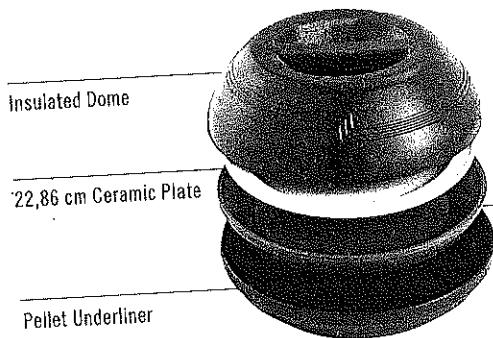

Camtherm® Thermal Pellet

- Holds heat at its core to keep hot foods at safe temperatures.
- Stays 11°C cooler on the edge than metal pellets to protect staff and patients from burns.
- Is a high-density plastic composite that won't dent like metal pellets.
- Holds a 22,86 cm plate.

MDS09, MDSL09 and MDCDB09EU: Colors: Meadow (447), Wheat (457) Speckled Gray (480), Cranberry (487) Navy Blue (497), Black (110).

MDSP9 Color: Dark Gray (477).
MDSP9 for use with CHPEL80.

MDSPLT9 Color: White (148).
MDSPLT9 Sold in full cases only.

MDSL9 and MDSP9 are NSF listed.

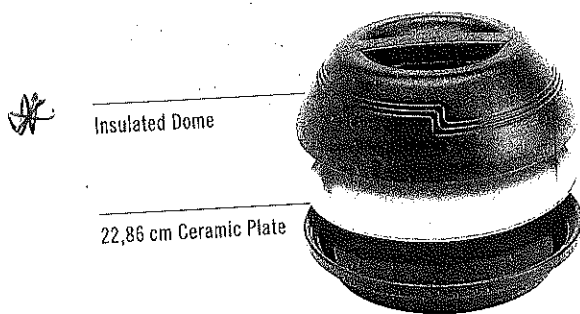

Heat Keeper Insulating Base

- Maintains heat for at least 20 minutes.
- Cost-effective solution to maintain meal delivery temperatures.
- Resists stains, odors and scratches.
- Holds a 22,86 cm plate.

MDS09, MDSL09 and HK39B Colors: Meadow (447), Wheat (457) Speckled Gray (480), Cranberry (487) Navy Blue (497), Black (110).

MDSPLT9 Color: White (148).
MDSPLT9 Sold in full cases only.

HK39B is NSF listed.

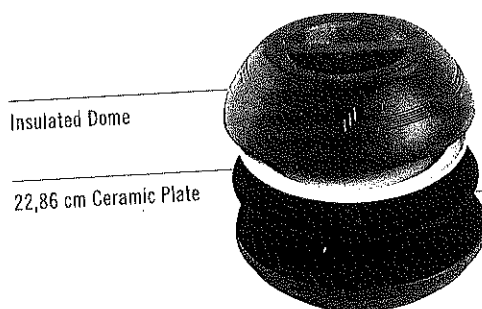

Camchiller® Cold Pellet

- Shatter-resistant at freezing temperature.
- Stackable for easy transport and storage.
- Fits 22,86 cm plate, Cambro® 22,86 cm plate cover and insulated dome.
- Can be used with or without an underliner.

MDS09 and MDSL9 Colors: Meadow (457), Speckled Gray (480), Cranberry (487), Navy Blue (497), Black (110).

MDSPC9 Color: Black (110).







MDSPLT9 Color: White (148).
MDSPLT9 Sold in full cases only.



HEALTHCARE DELIVERY WARE – THE SHORELINE COLLECTION

Induction® Complete Heat System









Most efficient heat retention solution, holds hot food at temperatures 60°C or higher for 45 minutes.

	 MDS09 	 MDSL09 	 MDSPLT9	 MDS09EU24V 
DESCRIPTION	Insulated dome covers 22,86 cm plate	Low profile insulated dome covers 22,86 cm plate	Ceramic plate	Camduction base holds 22,86 cm plate
OUTSIDE DIAMETER	25,94 cm	25,94 cm	22,86 cm	24,31 cm
HEIGHT	8,17 cm	6,99 cm	2,54 cm	2,26 cm
FULL-SIZE CAMRACK®	PR59314	PR59314	PR314	PR59314
CASE PACK	12	12	24	12

Domes and Delivery Ware are made of durable polypropylene and not designed for microwave use.







Therm® Thermal Pellet System

Perfect choice for maximum heat retention, holds temperature for 60 or more minutes.

	 MDS09 	 MDSL09 	 MDSL9 	 MDSPLT9	 MDS09 
DESCRIPTION	Insulated dome covers 22,86 cm plate	Low profile insulated dome covers 22,86 cm plate	Pellet underliner holds 24,13 cm pellet	Ceramic plate	Thermal pellet holds 22,86 cm plate
OUTSIDE DIAMETER	25,94 cm	25,94 cm	24,29 cm	22,86 cm	24 cm
HEIGHT	8,17 cm	6,99 cm	4,6 cm	2,54 cm	4,45 cm
FULL-SIZE CAMRACK	PR59314	PR59314	PR59314	PR314	PR59314
CASE PACK	12	12	12	24	12









Heat Keeper Insulating Base System

Most cost-effective solution for heat retention, holds temperature for 20 or more minutes.

	 MDS09 	 MDSL09 	 MDSPLT9	 HK39B 
DESCRIPTION	Insulated dome covers 22,86 cm plate	Low profile insulated dome covers 22,86 cm plate	Ceramic plate	Insulating base for 22,86 cm plate
OUTSIDE DIAMETER	25,94 cm	25,94 cm	22,86 cm	24,48 cm
HEIGHT	8,17 cm	6,99 cm	2,54 cm	4,07 cm
FULL-SIZE CAMRACK	PR59314	PR59314	PR314	PR59314
CASE PACK	12	12	24	12

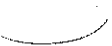
Camchiller® Cold Pellet System

Keeps cold food below or at 4°C for up to 45 minutes when used with a chilled plate and insulated dome.

	 MDS09 	 MDSL09 	 MDSPLT9	 New! MDSPC9 	 MDSL9 
DESCRIPTION	Insulated dome covers 22,86 cm plate	Camwear® Camcover®	Ceramic plate	Camchiller cold pellet holds 22,86 cm plate	Pellet underliner holds 24,13 cm pellet
OUTSIDE DIAMETER	25,94 cm	26,2 cm	22,86 cm	24,31 cm	24,29 cm
HEIGHT	8,17 cm	6,99 cm	2,54 cm	3,42 cm	4,6 cm
FULL-SIZE CAMRACK	PR59314	PR59314	PR314	PR59314	PR59314
CASE PACK	12	12	24	12	12