



AdvertQuote



Quotation Advert

Opening Date: 2022-02-25

Closing Date: 2022-03-04

Closing Time: 11:00

INSTITUTION DETAILS

Institution Name: Madadeni hospital

Province: KwaZulu-Natal

Department or Entity: Department of Health

Division or section: Central Supply Chain Management

Place where goods / services is required: Madadeni hospital

Date Submitted: 2022-02-25

ITEM CATEGORY AND DETAILS

Quotation Number: ZNQ:
MAD/881/22

Item Category: Services

Item Description: Upgrading of ablutions in OPD entrance and Main pharmacy
Requirements: CIDB GB and SO

Quantity (if supplies)

COMPULSORY BRIEFING SESSION / SITE VISIT

Select Type: Compulsory Briefing Session

Date: 2022-03-02

Time: 11:00 Late coming will not be entertained.

Venue: Madadadni Hospital, Maintenance

QUOTES CAN BE COLLECTED FROM: They have been uploaded together with the advert.

QUOTES SHOULD BE DELIVERED TO: They must be hand delivered at Madadeni hospital, in the Admin tender box.

ENQUIRIES REGARDING THE ADVERT MAY BE DIRECTED TO:

Name: Mr. AL Ntlangeni

Email:

Contact Number: 034 328 8269

Finance Manager Name: Mr MP Msomi

Finance Manager Signature:

No late quotes will be considered

OFFICIAL PRICE PAGE FOR QUOTATIONS

QUOTE NUMBER: MAD/881/22

DESCRIPTION: UPGRADING OF ABLUTIONS IN OPD ENTRANCE AND MAIN PHARMACY

SIGNATURE OF BIDDER DATE.....
 [By signing this document, I hereby agree to all terms and conditions]

CAPACITY UNDER WHICH THIS QUOTE IS SIGNED.....

Item No	Quantity	Description	Brand & model	Country of manufacture	Price	
					R	c
1	ONCE OFF	UPGRADING OF ABLUTIONS IN OPD ENTRANCE AND MAIN PHARMACY				
		REQUIREMENT: CIDB GB AND SO				
VALUE ADDED TAX @ 15% (Only if VAT Vendor)						
TOTAL QUOTATION PRICE (VALIDITY PERIOD 60 Days)						

Does This Offer Comply With The Specification? Is The Price Firm?	Does The Article Conform To The S.A.N.S. / S.A.B.S. Specification? State Delivery Period, e.g., 1day, 1week
--	--

<p>Enquiries regarding the quote may be directed to:</p> <p>Contact Person: <u>MR. AL NTLANGENI</u> Tel: <u>0343288269</u>.....</p> <p>E-Mail Address:</p>	<p>Enquiries regarding technical information may be directed to:</p> <p>Contact Person: <u>MR MBATHA</u>..... Tel: <u>0343288020</u>.....</p>
---	--

DECLARATION OF INTEREST

1. Any legal person, including persons employed by the state¹, or persons having a kinship with persons employed by the state, including a blood relationship, may make an offer or offers in terms of this invitation to quote (includes a price quotation, advertised competitive quote, limited quote or proposal). In view of possible allegations of favouritism, should the resulting quote, or part thereof, be awarded to persons employed by the state or to persons connected with or related to them, it is required that the bidder or his/her authorised representative declare his/her position in relation to the evaluating/adjudicating authority where-
 - the bidder is employed by the state; and/or
 - the legal person on whose behalf the bidding document is signed, has a relationship with persons/a person who are/is involved in the evaluation and or adjudication of the quote(s), or where it is known that such a relationship exists between the person or persons for or on whose behalf the declarant acts and persons who are involved with the evaluation and or adjudication of the quote.
2. In order to give effect to the above, the following questionnaire must be completed and submitted with the quote.

- 2.1. Full Name of bidder/representative.....
- 2.2. Identity Number:
- 2.3. Position occupied in the Company (director, trustee, shareholder²):
- 2.4. Company Registration Number:
- 2.5. Tax Reference Number:
- 2.6. VAT Registration Number:
- 2.7. The names of all directors / trustees / shareholders / members, their individual identity numbers, tax reference numbers and, if applicable, employee / persal numbers must be indicated in paragraph 3 below. [TICK APPLICABLE]
- 2.8. Are you or any person connected with the bidder presently employed by the state? YES NO
- 2.8.1. If so, furnish the following particulars:
 - Name of person / director / trustee / shareholder/ member:
 - Name of state institution at which you or the person connected to the bidder is employed:.....
 - Position occupied in the state institution:Any other particulars:.....
- 2.8.2. If you are presently employed by the state, did you obtain the appropriate authority to undertake remunerative work outside employment in the public sector? YES NO
- 2.8.2.1. If yes, did you attach proof of such authority to the quote document?
- (Note: Failure to submit proof of such authority, where applicable, may result in the disqualification of the quote.)*
- 2.8.2.2. If no, furnish reasons for non-submission of such proof:
- 2.9. Did you or your spouse, or any of the company's directors / trustees / shareholders / members or their spouses conduct business with the state in the previous twelve months? YES NO
- 2.9.1. If so, furnish particulars:.....
- 2.10. Do you, or any person connected with the bidder, have any relationship (family, friend, other) with a person employed by the state and who may be involved with the evaluation and or adjudication of this quote? YES NO
- 2.10.1. If so, furnish particulars:.....
- 2.11. Are you, or any person connected with the bidder, aware of any relationship (family, friend, other) between any other bidder and any person employed by the state who may be involved with the evaluation and or adjudication of this quote? YES NO
- 2.11.1. If so, furnish particulars:.....
- 2.12. Do you or any of the directors / trustees / shareholders / members of the company have any interest in any other related companies whether or not they are bidding for this contract? YES NO
- 2.12.1. If so, furnish particulars:.....

3. Full details of directors / trustees / members / shareholders.

NB: The Department Of Health will validate **details of directors / trustees / members / shareholders** on CSD. It is the suppliers' responsibility to ensure that their details are up-to-date and verified on CSD. If the Department cannot validate the **information** on CSD, the quote will not be considered and passed over as non-compliant according to National Treasury Instruction Note 4 (a) 2016/17.

4 DECLARATION

I, THE UNDERSIGNED (NAME).....CERTIFY THAT THE INFORMATION FURNISHED IN PARAGRAPHS 2.

I ACCEPT THAT THE STATE MAY REJECT THE QUOTE OR ACT AGAINST ME SHOULD THIS DECLARATION PROVE TO BE FALSE.

.....
Name of bidder	Signature	Position	Date

¹"State" means -

- | | |
|---|---|
| a) any national or provincial department, national or provincial public entity or constitutional institution within the meaning of the Public Finance Management Act, 1999 (Act No. 1 of 1999);
b) any municipality or municipal entity; | c) provincial legislature;
d) national Assembly or the national Council of provinces; or
e) Parliament. |
|---|---|

"Shareholder" means a person who owns shares in the company and is actively involved in the management of the enterprise or business and exercises control over the enterprise.

SPECIAL CONTRACT CONDITIONS OF QUOTATIONS

1. AMENDMENT OF CONTRACT

- 1.1. Any amendment to or renunciation of the provisions of the contract shall at all times be done in writing and shall be signed by both parties.

2. CHANGE OF ADDRESS

- 2.1. Bidders must advise the Department of Health (institution where the offer was submitted) should their address (*domicilium citandi et executandi*) details change from the time of bidding to the expiry of the contract.

3. GENERAL CONDITIONS ATTACHED TO THIS QUOTATION

- 3.1. The Department is under no obligation to accept the lowest or any quote.
- 3.2. The Department reserves the right to communicate in writing with vendors in cases where information is incomplete or where there are obscurities regarding technical aspects of the offer, to obtain confirmation of prices or preference claims in cases where it is evident that a typing, written, transfer or unit error has been made, to investigate the vendor's standing and ability to complete the supply/service satisfactorily.
- 3.3. **ALL DECISIONS TAKEN BY THE DEPARTMENT ARE FINAL, INCLUDING THE AWARD OF THIS QUOTATION.**
- 3.4. The price quoted must include VAT (if VAT vendor). However, it must be noted that the Department reserves the right to evaluate all quotations excluding VAT as some bidders may not be VAT vendors.
- 3.5. The bidder must ensure the correctness & validity of the quotation:
- (i) *that the price(s), rate(s) & preference quoted cover all for the work/item (s) & accept that any mistakes regarding the price (s) & calculations will be at the bidder's risk*
 - (ii) *it is the responsibility of the bidder to confirm receipt of their quotation and to keep proof thereof.*
- 3.6. The bidder must accept full responsibility for the proper execution & fulfilment of all obligations conditions devolving on under this agreement, as the Principal (s) liable for the due fulfilment of this contract.
- 3.7. This quotation will be evaluated based on the 80/20 points system, specification, correctness of information and/or functionality criteria. All required documentation must be completed in full and submitted.
- 3.8. Offers must comply strictly with the specification.
- 3.9. Only offers that meet or are greater than the specification will be considered.
- 3.10. Late offers will not be considered.
- 3.11. Expired product/s will not be accepted. All products supplied must be valid for a minimum period of six months.
- 3.12. Used/ second-hand products will not be accepted.
- 3.13. A bidder not registered on the Central Suppliers Database or whose verification has failed will not be considered.
- 3.14. All delivery costs must be included in the quoted price for delivery at the prescribed destination.
- 3.15. Only firm prices will be accepted. Such prices must remain firm for the contract period. Non-firm prices (including rates of exchange variations) will not be considered.
- 3.16. In cases where different delivery points influence the pricing, a separate pricing schedule must be submitted for each delivery point.
- 3.17. In the event of a bidder having multiple quotes, only the cheapest according to specification will be considered.
- 3.18. Verification will be conducted to identify if bidders have multiple companies and are cover-quoting for this bid.
- 3.19. In such instances, the Department reserves the right to immediately disqualify such bidders as cover-quoting is an offence that represents both corruption and acquisition fraud.

4. SPECIAL INSTRUCTIONS AND NOTICES TO BIDDERS REGARDING THE COMPLETION OF THIS QUOTATION.

- 4.1. Unless inconsistent with or expressly indicated otherwise by the context, the singular shall include the plural and vice versa and with words importing the masculine gender shall include the feminine and the neuter.
- 4.2. Under no circumstances whatsoever may the quotation/bid forms be retyped or redrafted. Photocopies of the original bid documentation may be used, but an original signature must appear on such photocopies.
- 4.3. The bidder is advised to check the number of pages and to satisfy himself that none are missing or duplicated.
- 4.4. Quotations submitted must be complete in all respects. However, where it is identified that information in a bidder's response is incomplete in any respect, the said supplier meets all specification requirements and is lowest to quote, the Department reserves the right to request the bidder to complete/submit such information.
- 4.5. Any alteration made by the bidder must be initialled; failure to do so may render the response invalid.
- 4.6. Use of correcting fluid is prohibited and may render the response invalid.
- 4.7. Quotations will be opened in public as soon as practicable after the closing time of quotation.
- 4.8. Where practical, prices are made public at the time of opening quotations.
- 4.9. If it is desired to make more than one offer against any individual item, such offers should be given on a photocopy of the page in question. Clear indication thereof must be stated on the schedules attached.
- 4.10. The Department is under no obligation to pay suppliers in part for work done if the supplier can no longer for fulfil their obligation.

5. SPECIAL INSTRUCTIONS REGARDING HAND DELIVERED QUOTATIONS

- 5.1. Quotation shall be lodged at the address indicated not later than the closing time specified for their receipt, and in accordance with the directives in the quotation documents.
- 5.2. Each quotation shall be addressed in accordance with the directives in the quotation documents and shall be lodged in a separate sealed envelope, with the name and address of the bidder, the quotation number and closing date indicated on the envelope. The envelope shall not contain documents relating to any quotation other than that shown on the envelope. If this provision is not complied with, such quotations/bids may be rejected as being invalid.
- 5.3. All quotations received in sealed envelopes with the relevant quotation numbers on the envelopes are kept unopened in safe custody until the closing time of the quotation/bids. Where, however, a quotation is received open, it shall be sealed. If it is received without a quotation/bid number on the envelope, it shall be opened, the quotation number ascertained, the envelope sealed and the quotation number written on the envelope.
- 5.4. A specific box is provided for the receipt of quotations, and no quotation found in any other box or elsewhere subsequent to the closing date and time of quotation will be considered.
- 5.5. No quotation/bid sent through the post will be considered if it is received after the closing date and time stipulated in the quotation documentation, and proof of posting will not be accepted as proof of delivery.
- 5.6. Quotation documents must not be included in packages containing samples. Such quotations may be rejected as being invalid.

6. SAMPLES

- 6.1. In the case of the quote document stipulating that samples are required, the supplier will be informed in due course when samples should be provided to the institution. (This decreases the time of safety and storage risk that may be incurred by the respective institution). The bidders sample will be retained if such bidder wins the contract.
 - (i) If a company/s who has not won the quote requires their samples, they must advise the institution in writing of such.
 - (ii) If samples are not collected within three months of close of quote the institution reserves the right to dispose of them at their discretion.
- 6.2. **Samples must be made available when requested in writing or if stipulated on the document.**
 - (i) If a Bidder fails to provide a sample of their product on offer for scrutiny against the set specification when requested, their offer will be rejected. All testing will be for the account of the bidder.

7. COMPULSORY SITE INSPECTION / BRIEFING SESSION

- 7.1. Bidders who fail to attend the compulsory meeting will be disqualified from the evaluation process.
 - (i) The institution has determined that a compulsory site meeting take place
 - (ii) Date / / Time : Place

Institution Stamp:	Institution Site Inspection / briefing session Official Full Name: Signature: Date:
--------------------	--

8. STATEMENT OF SUPPLIES AND SERVICES

- 8.1. The contractor shall, when requested to do so, furnish particulars of supplies delivered or services executed. If he/she fails to do so, the Department may, without prejudice to any other rights which it may have, institute inquiries at the expense of the contractor to obtain the required particulars.

9. SUBMISSION AND COMPLETION OF SBD 6.1

- 9.1. Should a bidder wish to qualify for preference points they must complete a SBD 6.1 document. Failure by a bidder to provide all relevant information required, will result in such a bidder not being considered for preference point's allocation. The preferences applicable on the closing date will be utilized. Any changes after the closing date will not be considered for that particular quote.

10. TAX COMPLIANCE REQUIREMENTS

- 10.1. In the event that the tax compliance status has failed on CSD, **it is the suppliers' responsibility to provide a SARS pin in order for the institution to validate the tax compliance status of the supplier.**
- 10.2. In the event that the institution cannot validate the suppliers' tax clearance on SARS as well as the Central Suppliers Database, **the quote will not be considered and passed over as non-compliant according to National Treasury Instruction Note 4 (a) 2016/17.**

11. TAX INVOICE

11.1. A tax invoice shall be in the currency of the Republic of South Africa and shall contain the following particulars:

- | | |
|--|--|
| (i) the name, address and registration number of the supplier; | (iv) a description and quantity or volume of the goods or services supplied; |
| (ii) the name and address of the recipient; | (v) the official department order number issued to the supplier; |
| (iii) an individual serialized number and the date upon which the tax invoice is issued; | (vi) the value of the supply, the amount of tax charged; |
| | (vii) the words tax invoice in a prominent place. |

12. PATENT RIGHTS

The supplier shall indemnify the **KZN Department of Health** (hereafter known as the purchaser) against all third-party claims of infringement of patent, trademark, or industrial design rights arising from use of the goods or any part thereof by the purchaser.

13. PENALTIES

- 13.1. If at any time during the contract period, the service provider is unable to perform in a timely manner, the service provider must notify the institution in writing/email of the cause of and the duration of the delay. Upon receipt of the notification, the institution should evaluate the circumstances and, if deemed necessary, the institution may extend the service provider's time for performance.
- 13.2. In the event of delayed performance that extends beyond the delivery period, the institution is entitled to purchase commodities of a similar quantity and quality as a substitution for the outstanding commodities, without terminating the contract, as well as return commodities delivered at a later stage at the service provider's expense.
- 13.3. Alternatively, the institution may elect to terminate the contract and procure the necessary commodities in order to complete the contract. In the event that the contract is terminated the institution may claim damages from the service provider in the form of a penalty. The service provider's performance should be captured on the service provider database in order to determine whether or not the service provider should be awarded any contracts in the future.
- 13.4. If the supplier fails to deliver any or all of the goods or to perform the services within the period(s) specified in the contract, the purchaser shall, without prejudice to its other remedies under the contract, deduct from the contract price, as a penalty, a sum calculated on the delivered price of the delayed goods or unperformed services using the current prime interest rate calculated for each day of the delay until actual delivery or performance.

14. TERMINATION FOR DEFAULT

- 14.1. The purchaser, without prejudice to any other remedy for breach of contract, by written notice of default sent to the supplier, may terminate this contract in whole or in part:
- (i) if the supplier fails to deliver any or all of the goods within the period(s) specified in the contract,
 - (ii) if the supplier fails to perform any other obligation(s) under the contract; or
 - (iii) if the supplier, in the judgment of the purchaser, has engaged in corrupt or fraudulent practices in competing for or in executing the contract.
- 14.2. In the event the purchaser terminates the contract in whole or in part, the purchaser may procure, upon such terms and in such manner as it deems appropriate, goods, works or services similar to those undelivered, and the supplier shall be liable to the purchaser for any excess costs for such similar goods, works or services.
- 14.3. Where the purchaser terminates the contract in whole or in part, the purchaser may decide to impose a restriction penalty on the supplier by prohibiting such supplier from doing business with the public sector for a period not exceeding 10 years.

15. FAILURE TO COMPLY WITH ABOVE WILL RESULT IN YOUR QUOTE BEING PASSED OVER.

PREFERENCE POINTS CLAIM FORM IN TERMS OF THE PREFERENTIAL PROCUREMENT REGULATIONS 2017

This preference form must form part of all quotes invited. It contains general information and serves as a claim form for preference points for Broad-Based Black Economic Empowerment (B-BBEE) Status Level of Contribution

NB: BEFORE COMPLETING THIS FORM, BIDDERS MUST STUDY THE GENERAL CONDITIONS, DEFINITIONS AND DIRECTIVES APPLICABLE IN RESPECT OF B-BBEE, AS PRESCRIBED IN THE PREFERENTIAL PROCUREMENT REGULATIONS, 2017.

1. GENERAL CONDITIONS

1.1 The following preference point systems are applicable to all quotes:

- the 80/20 system for requirements with a Rand value of up to R50 000 000 (all applicable taxes included); and

1.2 The value of this quote is estimated to not exceed R50 000 000 (all applicable taxes included) and therefore the 80/20 preference point system shall be applicable.

1.3 Points for this quote shall be awarded for:

- (a) Price; and
- (b) B-BBEE Status Level of Contributor.

1.4 The maximum points for this quote is allocated as follows:

	POINTS
PRICE	80
B-BBEE STATUS LEVEL OF CONTRIBUTOR	20
Total points for Price and B-BBEE must not exceed	100

1.5 Failure on the part of a bidder to submit proof of B-BBEE Status level of contributor together with the quote, will be interpreted to mean that preference points for B-BBEE status level of contribution are not claimed.

1.6 The purchaser reserves the right to require of a bidder, either before a quote is adjudicated or at any time subsequently, to substantiate any claim in regard to preferences, in any manner required by the purchaser.

2. DEFINITIONS

- (a) **"B-BBEE"** means broad-based black economic empowerment as defined in section 1 of the Broad-Based Black Economic Empowerment Act;
- (b) **"B-BBEE status level of contributor"** means the B-BBEE status of an entity in terms of a code of good practice on black economic empowerment, issued in terms of section 9(1) of the Broad-Based Black Economic Empowerment Act;
- (c) **"bid"** means a written offer in a prescribed or stipulated form in response to an invitation by an organ of state for the provision of goods or services, through price quotations, advertised competitive bidding processes or proposals;
- (d) **"Broad-Based Black Economic Empowerment Act"** means the Broad-Based Black Economic Empowerment Act, 2003 (Act No. 53 of 2003);
- (e) **"EME"** means an Exempted Micro Enterprise in terms of a code of good practice on black economic empowerment issued in terms of section 9 (1) of the Broad-Based Black Economic Empowerment Act;
- (f) **"functionality"** means the ability of a tenderer to provide goods or services in accordance with specifications as set out in the tender documents.
- (g) **"prices"** includes all applicable taxes less all unconditional discounts;
- (h) **"proof of B-BBEE status level of contributor"** means:
 - 1) B-BBEE Status level certificate issued by an authorized body or person;
 - 2) A sworn affidavit as prescribed by the B-BBEE Codes of Good Practice;
 - 3) Any other requirement prescribed in terms of the B-BBEE Act;
- (i) **"QSE"** means a qualifying small business enterprise in terms of a code of good practice on black economic empowerment issued in terms of section 9 (1) of the Broad-Based Black Economic Empowerment Act;
- (j) **"rand value"** means the total estimated value of a contract in Rand, calculated at the time of bid invitation, and includes all applicable taxes;

3. POINTS AWARDED FOR PRICE

3.1 THE 80/20 PREFERENCE POINT SYSTEMS

A maximum of 80 points is allocated for price on the following basis:

$$P_s = 80 \left(1 - \frac{P_t - P_{\min}}{P_{\min}} \right) \text{ Where}$$

- P_s = Points scored for price of bid under consideration
- P_t = Price of bid under consideration
- P_{min} = price of lowest acceptable bid

4. POINTS AWARDED FOR B-BBEE STATUS LEVEL OF CONTRIBUTOR

4.1 In terms of Regulation 6 (2) and 7 (2) of the Preferential Procurement Regulations, preference points must be awarded to a bidder for attaining the B-BBEE status level of contribution in accordance with the table below:

B-BBEE Status Level of Contributor	Number of points (80/20 system)
1	20
2	18
3	14
4	12
5	8
6	6
7	4
8	2
Non-compliant contributor	0

5. BID DECLARATION

5.1 Bidders who claim points in respect of B-BBEE Status Level of Contribution must complete the following:

6. B-BBEE STATUS LEVEL OF CONTRIBUTOR CLAIMED IN TERMS OF PARAGRAPHS 1.4 AND 4.1

6.1 B-BBEE Status Level of Contributor: =(maximum of 20 points)

(Points claimed in respect of paragraph 7.1 must be in accordance with the table reflected in paragraph 4.1 and must be substantiated by relevant proof of B-BBEE status level of contributor.

7. SUB-CONTRACTING
applicable box)

(Tick

YES		NO	
-----	--	----	--

7.1 Will any portion of the contract be sub-contracted?

7.1.1 If yes, indicate:

- i) What percentage of the contract will be subcontracted.....%
- ii) The name of the sub-contractor.....
- iii) The B-BBEE status level of the sub-contractor.....

8. Whether the sub-contractor is an EME or QSE

(Tick applicable box)

iv) Specify, by ticking the appropriate box, if subcontracting with an enterprise in terms of Preferential Procurement Regulations,2017:

YES		NO	
-----	--	----	--

Designated Group: An EME or QSE which is at least 51% owned by:	EME √	QSE √
Black people		
Black people who are youth		
Black people who are women		
Black people with disabilities		
Black people living in rural or underdeveloped areas or townships		
Cooperative owned by black people		
Black people who are military veterans		
OR		
Any EME		

9. DECLARATION WITH REGARD TO COMPANY/FIRM

9.1 Name of company/firm:.....

9.2 VAT registration number:.....

9.3 Company registration number:.....

9.4 TYPE OF COMPANY/ FIRM [TICK APPLICABLE BOX]

- Partnership/Joint Venture / Consortium
- One person business/sole propriety
- ~~Close corporation~~
- Company
- (Pty) Limited

9.5 DESCRIBE PRINCIPAL BUSINESS ACTIVITIES

.....

9.6 COMPANY CLASSIFICATION [TICK APPLICABLE BOX]

- Manufacturer
- Supplier
- Professional service provider
- Other service providers, e.g. transporter, etc.

9.7 Total number of years the company/firm has been in business:.....

9.8 I/we, the undersigned, who is / are duly authorised to do so on behalf of the company/firm, certify that the points claimed, based on the B-BBE status level of contributor indicated in paragraphs 1.4 and 6.1 of the foregoing certificate, qualifies the company/ firm for the preference(s) shown and I / we acknowledge that:

- i) The information furnished is true and correct;
- ii) The preference points claimed are in accordance with the General Conditions as indicated in paragraph 1 of this form;
- iii) In the event of a contract being awarded as a result of points claimed as shown in paragraphs 1.4 and 6.1, the contractor may be required to furnish documentary proof to the satisfaction of the purchaser that the claims are correct;
- iv) If the B-BBEE status level of contributor has been claimed or obtained on a fraudulent basis or any of the conditions of contract have not been fulfilled, the purchaser may, in addition to any other remedy it may have –
 - (a) disqualify the person from the bidding process;
 - (b) recover costs, losses or damages it has incurred or suffered as a result of that person's conduct;
 - (c) cancel the contract and claim any damages which it has suffered as a result of having to make less favourable arrangements due to such cancellation;
 - (d) recommend that the bidder or contractor, its shareholders and directors, or only the shareholders and directors who acted on a fraudulent basis, be restricted by the National Treasury from obtaining business from any organ of state for a period not exceeding 10 years, after the *audi alteram partem* (hear the other side) rule has been applied; and
 - (e) forward the matter for criminal prosecution.

<p>WITNESSES</p> <p>1.</p> <p>2.</p>

<p>.....</p> <p>SIGNATURE(S) OF BIDDERS(S)</p> <p>DATE:</p> <p>ADDRESS.....</p> <p>.....</p> <p>.....</p>
--



PROVINCE OF KWAZULU-NATAL

DEPARTMENT OF HEALTH

**Upgrade Ablution Facility OPD Entrance And Mini Pharmacy
to Dis-abled Facility**

MADADENI HOSPITAL

ZNQ NO: _____

Closing Date & Time	:	@ 11h00
Contract Period	:	01 WEEK
Validity Period	:	60 Days
Technical Contact Person	:	MR. SV Mbatha
Contact Telephone Number	:	034 328 8020
On Site Inspection	:	

WORK DISCIPLINE:

This is a multi-disciplinary Contract and Contractors should only tender for services in respect of their own area/s of expertise. The Tenderer shall in the Schedule of Information, and by way of supplementary information, satisfy the Head of Department or his or her designee that sufficient equipment is possessed to execute the services, or an indication shall be given as to the manner in which such equipment would be sourced. Should the Tenderer not be able to prove possession of, or ability to access, sufficient equipment, the Tender will be wholly disqualified. The Head of Department or his or her designee reserves the right to investigate the existence and/or proposed sourcing of equipment.

The Tenderer also will be required to satisfy the Head of Department or his or her designee that a sufficient/qualified and experienced labour force is employed, or that sufficient

experienced labour can be acquired, to complete the services and produce a fair quality of workmanship. The Tenderer will be required to produce adequate and sufficient references to enable the Head of Department or his or her designee to inspect previously completed work and assess the capacity of the Tenderer.

The Head of Department or his or her designee reserves the right to recommend that Tenderers execute work of only certain types and up to certain capacities due to the limitations of experience and skills of the Tenderer. Any limitations to such work tendered for will be recommended to the Central Procurement Committee for approval and will be applied strictly during the contract period.

The successful Tenderer shall supply all materials, labour, tools and plant etc., necessary to carry out maintenance, repairs, servicing, upgrading, replacement, and minor new works to buildings.

PROVINCE OF KWAZULU-NATAL
DEPARTMENT OF HEALTH

MADADENI HOSPITAL

ZNQ NO:

**Upgrade Ablution Facility OPD Entrance And Mini Pharmacy
to Dis-abled Facility**

PROJECT SPECIFICATIONS

1. NOTES TO TENDERERS

1.1. SCOPE OF CONTRACT

This Contract is for the complete execution of the project indicated above.

1.2. CONDITIONS OF CONTRACT AND PRELIMINARIES

1.2.1 PERIOD OF CONTRACT

04 Weeks as the Contract Period for the completion of *all Works* from date of Site handover.

1.2.2 CONTRACT GUARANTEE:

The successful Tenderer will **NOT** be required to submit a contract guarantee.

1.2.3 GUARANTEE PERIOD

The guarantee period for *all Works* and all materials must be for a minimum of **One (1) Year** from the date of first delivery. UNLES SPECIFIED

1.2.4 SITE AND MODE OF PROCEDURE

The work contained in this contract will be carried out on the site of the existing Institution.

The Contractor is advised that the existing premises will be occupied throughout the period of the contract.

Damage to existing buildings - Tenderers to note that any damages done or occurring to any of the buildings will be repaired at the expense of the contractor/ Tenderer.

The repairs must be to the satisfaction of the KwaZulu- Natal Department of Health.

ALL RUBBLE TO REMOPVED OF SITE ON A DAILY BASIS

1.2.5 SATISFACTORY INSTALLATION

The whole of the installation shall be carried out in accordance with the South African Bureau of Standards Code of Practice for the application of National Building Regulations, the KZNPA Standard Preambles to all Trades, REGULATION R158, the KZNPA General Electrical Specification, the South African Bureau of Standards Code of Practice for the Wiring of Premises 0142-1 and the Occupational Health and Safety Act 85 of 1993 as amended.

Copies of the KZNPA Standard Preambles to all Trades and the KZNPA General Electrical Specification are available at the office of the Secretary for Health – KwaZulu-Natal and can be obtained on request.

1.2.6 CERTIFICATE OF COMPLIANCE

**NB: COC will be required for any electrical work done
CIBD: GB/ SO
Certificate of a qualified Plumber**

1.2.7 Health and safety act 85(1993)

Safety file must be produced and handed to safety department before commencement

PROVINCE OF KWAZULU-NATAL
DEPARTMENT OF HEALTH

**Upgrade Ablution Facility OPD Entrance And Mini Pharmacy
to Dis-abled Facility**

MADADENI HOSPITAL

ZNQ NO: _____

TECHNICAL SPECIFICATIONS

2. TECHNICAL SPECIFICATION

2.1 GENERAL

This TECHNICAL SPECIFICATION shall be read in conjunction with all other sections of the SPECIFICATION and cognisance shall be taken of the clauses relevant to this particular installation, whether any specific clauses are referred to or not.

SPECIFICATION

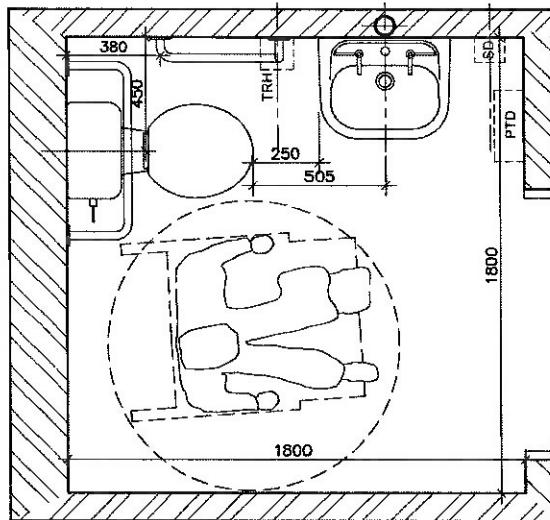

TYPICAL ACCESS TOILET

SOME ARRANGEMENTS MAY DIFFER

VAAL SANITARYWARE VITREOUS CHINA PEARL PARAPLEGIC SEMI CLOSE COUPLED WC CODE 7300SC COMPLETE WITH APPROVED TOILET SEAT
CHAIRMAN INDUSTRIES GRAB RAILS POSITIONED AS INDICATED
CISTERN BACK RAIL SR2A PARAPLEGIC D12

VAAL SANITARYWARE DAISY VITREOUS CHINA WALL MOUNTED BASIN COLOUR WHITE (CODE: 7008), SIZE 510 X 400MM WITH SEMI PUNCHED TAP HOLES, INTEGRATED OVERFLOW BOLTED TO WALL WITH TWO 10MM BOLTS (CODE: B44820) AND SEALED WITH SILICONE SEALANT WHERE BASIN MEETS WALL

HOT & COLD COBRA WATERTECH 605-218 MEDICAL ELBOW ACTION PILLAR TAPS, SQUARE TYPE
MANUFACTURED IN ACCORDANCE WITH SANS 226:2004 TYPE 2.
COLD TAP CLOSEST TO WC

TYPICAL PLAN

MIRROR 400 x 900 BEVELED EDGED MIRROR WITH DOMED CAPPED SCREWS

PAPER TOWEL DISPENSER TYPE 1 - SERRA FLAT FOLDED PAPER TOWEL DISPENSER COMPLETE WITH LOCK & KEY GRADE 304 STAINLESS STEEL SATIN FINISH A735 WITH 450 C FOLD TOWEL CAPACITY SUPPLIED WITH SERRA DISPOSOR SLIMLINE WALL BIN IN SATIN STAINLESS STEEL FINISH.

SOAP DISPENSER TYPE B - SERRA NOX3 GRADE 304 STAINLESS STEEL SATIN FINISH SOAP DISPENSER WITH 1.25L CAPACITY SUPPLIED COMPLETE WITH KEY

TOILET ROLL HOLDER SERRA ROL TR2 GRADE 304 SATIN FINISH STAINLESS STEEL WITH SNAPLOCK & KEY

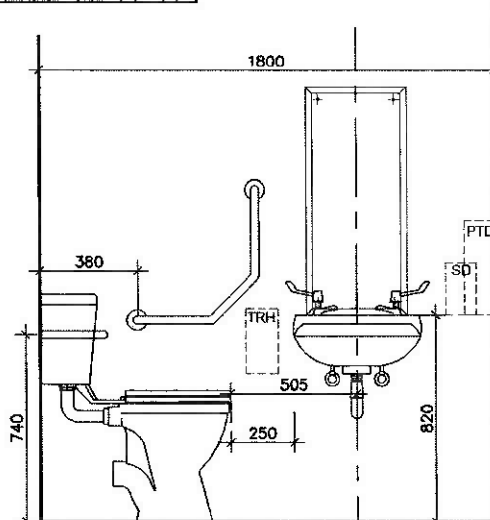

TYPICAL ELEVATION

Scope of work

OPD

1. Brick up wall between wash basin and ablutions to roof height at OPD
2. ~~Remove wash hand basin and install closed coupled toilet cistern complete~~ with water supply and drainage
3. Install hand wash basin in same area , complete with water supply and drain
4. In two existing ablutions , remove toilet cisterns complete
5. Break up wall between the two ablutions
6. Supply and install dis-abled toilet cistern (SEE ATTACHED SPECIFICATION WHIH MUST BE ADDERED TO) complete with fittings and accessories, coupled up to drain and water supply
7. Supply and install hand wash basin, complete with elbow action medical mixer, connected to water supply and drain
8. Break up wall to accommodate for dis-abled entrance with door and frame

MINI PHARMACY

1. Remove bath tub , wash basin and shower
2. Break up walls to make one open space
3. In area accommodate for one dis-abled toilet and one normal toilet complete with water supply and drainage
4. Make good to all tiling
5. Supply and install Hygia wash basin with medical elbow mixers
6. Tile walls and floor

SCHEDULE OF RATES

WORK TO BE DONE AT MADADENI HOSPITAL - SCHEDULE OF PRICES:

Item	DESCRIPTION	UNIT	QTY	RATE/UNIT		TOTAL	
				R	c	R	c
	INSTITUTION: MADADENI HOSPITAL						
	ZNO NO:						
	All rates quoted shall be inclusive of transport, Labour and profit. The Tenderer is advised that the buildings are occupied						
	PROPRIETARY ARTICLES:						
	All equipment and material used in this contract shall be that which is specified or other SABS approved.						
	OPD ENTRANCE ABLUTIONS						
1.	STAFF TOILETS						
	Brick up wall with single brick wall	m ²	3				
	Install closed coupled toilet cistern complete with water supply and drainage	each					
	RE-Position hand wash basin complete with water supply and drainage	m ²					
	Tile walls and floor	m ²					
2.	OPD COMMUNITY ABLUTIONS MALE/FEMALE						
	Remove both male and female toilet cisterns complete	each	2				
	Demolish wall between male and female ablutions	m ²					
	Convert area to accommodate for one disabled (SEE ATTACHED SPECIFICATION) toilet and one normal toilet, complete with water supply and drainage	each	2				
	Tile walls and floor						
TOTAL						R	

CARRIED TO COLLECTION SUMMARY

PS 1

Item	DESCRIPTION	UNIT	QTY	RATE/UNIT		TOTAL	
				R	c	R	c
3.	MINI PHARMACY						
	Remove bath tub . shower and wash basin	item					
	Break up shower wall, and make good to floor and walls	item					
	Convert area to accommodate for one dis- abled (SEE ATTACHED SPECIFICATION)toilet and one normal toilet , complete with water supply and drainage	each	2				
4.	Tile walls and floor						
5.							
CARRIED TO COLLECTION SUMMARY				PS 2	TOTAL	R	

COLLECTION SUMMARY

PROJECT
DESCRIPTION:

**Upgrade Ablution Facility OPD Entrance
And Mini Pharmacy to Dis-abled Facility**

ZNQ NO: _____

NOTE:

THIS COLLECTION SUMMARY MUST BE COMPLETED IN FULL BY THE CONTRACTOR AND RETURNED TOGETHER WITH THE QUOTATION FORM.

Collection Summary	PS 1	R	
Collection Summary	PS 2	R	
Safety Requirements		R	
Sub total		R	



Mr. SV Mbatha
Chief Artisan

18/12/2021
Date



Mr. AN Ndamane
Deputy Director Systems

13/12/2021
Date

Mr C Zwane
Assistant Director SCM

Date

Company Director/ Company name

MADADENI HOSPITAL-Maintenance
Project Policy

**Upgrade Ablution Facility OPD Entrance And Mini Pharmacy
to Dis-abled Facility**

1. ~~Stores issue the Company an order number and company confirms.~~
2. Stores notify the maintenance department
3. The Company contacts the maintenance department within a period of 2 days to confirm that they have received an order number.
4. Company is given a period of 1 week to compile and submit a work plan, safety requirements as briefed by a safety officer (**In a table form**) (Only 1 Week will be given to complete this project)
5. Presentation of an official order, work plan or Program
6. No work will be commenced without submitting a work plan and a safety plan.
7. There will be progress meeting every week depending on the project period.

Mr. SV Mbatha
Chief Artisan

Date

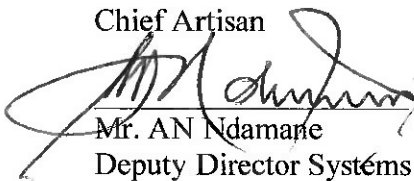

Mr. AN Ndamane
Deputy Director Systems

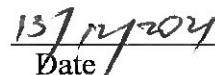

Date

Mr T Zwane
Assistant Director SCM

Date

Company Director/ Company name

PROVINCE OF KWAZULU-NATAL
DEPARTMENT OF HEALTH

**Upgrade Ablution Facility OPD Entrance And Mini Pharmacy
to Dis-abled Facility**

ZNO NO: _____

SCHEDULE OF RATES

3.1 ITEMS AND PRICING

The Department reserves the right to place an order for any quantities of items included in the Schedules. The Schedule of Rates must also not be assumed to include and describe every detail of the supply requirement, but must be taken and read in conjunction with the other parts of the document. Thus the supplier shall not have claim for further payment in respect of any order which may be described or implied in the contract, although apparently no corresponding items are given in the Schedule of Rates. The supplier shall be deemed to have satisfied himself before quoting as to the correctness and sufficiency of his quote for the contract and of the rates and prices stated in the Schedule of Rates.

3.2 TAX AND DUTIES

Prices, quoted and paid, must include all customs, excise and import duties, and any other tariffs or taxes levied by the government or statutory body having jurisdiction on the goods provided under this contract, including Value Added Tax (applicable to the current rate).

3.3 RATES

Except where provision is made in the Schedule of Rates, the rates and prices inserted shall be the full rates and prices for the service delivered described under the respective items and shall cover all labour, transport, overhead charges and profit, etc. as well as the general liabilities, obligations and risks arising out of the Conditions of Contract, the overhead charges and profit being spread proportionately over the rates of the relative items in the Schedule of Rates

