

SharePoint

Osindisweni Hospital PROC 1 ▾ ?



KZN HEALTH

KZN Health Intranet

Search this site

[HOME](#) [CORPORATE INFORMATION](#) [COMPONENTS](#) [DIRECTORY](#) [DISTRICT OFFICES](#) [HEALTH FACILITIES](#)

KZN Health > Components > Supply Chain Management

AdvertQuote

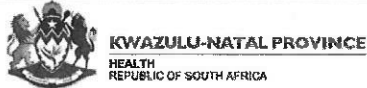

Quotation Advert

Opening Date:	<input type="text" value="2022-10-18"/>
Closing Date:	<input type="text" value="2022-10-21"/>
Closing Time:	<input type="text" value="11:00"/>
INSTITUTION DETAILS	
Institution Name:	<input type="text" value="Osindisweni hospital"/>
Province:	<input type="text" value="KwaZulu-Natal"/>
Department or Entity:	<input type="text" value="Department of Health"/>
Division or section:	<input type="text" value="Central Supply Chain Management"/>
Place where goods / services is required	<input type="text" value="Osindisweni Hospital , Oakford Road , Verulam..4340"/>
Date Submitted	<input type="text" value="2022-10-18"/>
ITEM CATEGORY AND DETAILS	
Quotation Number:	ZNQ: <input type="text" value="OSI 221-22-23"/>
Item Category:	<input type="text" value="Goods"/>
Item Description:	<input type="text" value="Coughing Booth"/>
Quantity (if supplies)	<input type="text" value="01"/>
COMPULSORY BRIEFING SESSION / SITE VISIT	
Select Type:	<input type="text" value="Not Applicable"/>
Date :	<input type="text"/>
Time:	<input type="text"/>
Venue:	<input type="text"/>
QUOTES CAN BE COLLECTED FROM:	<input type="text" value="print from website"/>
QUOTES SHOULD BE DELIVERED TO:	<input type="text" value="Osindisweni Hospital in Box near security main gate"/>
ENQUIRIES REGARDING THE ADVERT MAY BE DIRECTED TO:	
Name:	<input type="text" value="Mr N E Shange"/>
Email:	<input type="text" value="NO e-mailed Quotes Accepted = Only FAX and Drop off"/>
Contact Number:	<input type="text" value="032-5419342"/>
Finance Manager Name:	<input type="text" value="Mr M.J. MTHEMBU"/>
Finance Manager Signature:	

No late quotes will be considered

DECLARATION OF INTEREST

- 1. Any legal person, including persons employed by the state...
2. In order to give effect to the above, the following questionnaire must be completed and submitted with the quote.

- 2.1. Full Name of bidder/representative...
2.2. Identity Number...
2.3. Position occupied in the Company...
2.4. Company Registration Number...
2.5. Tax Reference Number...
2.6. VAT Registration Number...

2.7. The names of all directors / trustees / shareholders / members, their individual identity numbers, tax reference numbers and, if applicable, employee / persal numbers must be indicated in paragraph 3 below. [TICK APPLICABLE]

2.8. Are you or any person connected with the bidder presently employed by the state? YES NO

2.8.1. If so, furnish the following particulars: Name of person / director / trustee / shareholder/ member...
Name of state institution at which you or the person connected to the bidder is employed...
Position occupied in the state institution... Any other particulars...

2.8.2. If you are presently employed by the state, did you obtain the appropriate authority to undertake remunerative work outside employment in the public sector? YES NO

2.8.2.1. If yes, did you attach proof of such authority to the quote document?

(Note: Failure to submit proof of such authority, where applicable, may result in the disqualification of the quote.)

2.8.2.2. If no, furnish reasons for non-submission of such proof:

2.9. Did you or your spouse, or any of the company's directors / trustees / shareholders / members or their spouses conduct business with the state in the previous twelve months? YES NO

2.9.1. If so, furnish particulars:.....

2.10. Do you, or any person connected with the bidder, have any relationship (family, friend, other) with a person employed by the state and who may be involved with the evaluation and or adjudication of this quote? YES NO

2.10.1. If so, furnish particulars:.....

2.11. Are you, or any person connected with the bidder, aware of any relationship (family, friend, other) between any other bidder and any person employed by the state who may be involved with the evaluation and or adjudication of this quote? YES NO

2.11.1. If so, furnish particulars:.....

2.12. Do you or any of the directors / trustees / shareholders / members of the company have any interest in any other related companies whether or not they are bidding for this contract? YES NO

2.12.1. If so, furnish particulars:.....

3. Full details of directors / trustees / members / shareholders.

NB: The Department Of Health will validate details of directors / trustees / members / shareholders on CSD. It is the suppliers' responsibility to ensure that their details are up-to-date and verified on CSD. If the Department cannot validate the information on CSD, the quote will not be considered and passed over as non-compliant according to National Treasury Instruction Note 4 (a) 2016/17.

4 DECLARATION

I, THE UNDERSIGNED (NAME).....CERTIFY THAT THE INFORMATION FURNISHED IN PARAGRAPHS 2.

I ACCEPT THAT THE STATE MAY REJECT THE QUOTE OR ACT AGAINST ME SHOULD THIS DECLARATION PROVE TO BE FALSE.

Name of bidder Signature Position Date

"State" means -
a) any national or provincial department, national or provincial public entity or constitutional institution within the meaning of the Public Finance Management Act, 1999 (Act No. 1 of 1999);
b) any municipality or municipal entity;
c) provincial legislature;
d) national Assembly or the national Council of provinces; or
e) Parliament.
"Shareholder" means a person who owns shares in the company and is actively involved in the management of the enterprise or business and exercises control over the enterprise.

SPECIAL CONTRACT CONDITIONS OF QUOTATIONS

1. AMENDMENT OF CONTRACT

- 1.1. Any amendment to or renunciation of the provisions of the contract shall at all times be done in writing and shall be signed by both parties.

2. CHANGE OF ADDRESS

- 2.1. Bidders must advise the Department of Health (institution where the offer was submitted) should their address (*domicilium citandi et executandi*) details change from the time of bidding to the expiry of the contract.

3. GENERAL CONDITIONS ATTACHED TO THIS QUOTATION

- 3.1. The Department is under no obligation to accept the lowest or any quote.
- 3.2. The Department reserves the right to communicate in writing with vendors in cases where information is incomplete or where there are obscurities regarding technical aspects of the offer, to obtain confirmation of prices or preference claims in cases where it is evident that a typing, written, transfer or unit error has been made, to investigate the vendor's standing and ability to complete the supply/service satisfactorily.
- 3.3. **ALL DECISIONS TAKEN BY THE DEPARTMENT ARE FINAL, INCLUDING THE AWARD OF THIS QUOTATION.**
- 3.4. The price quoted must include VAT (if VAT vendor). However, it must be noted that the Department reserves the right to evaluate all quotations excluding VAT as some bidders may not be VAT vendors.
- 3.5. The bidder must ensure the correctness & validity of the quotation:
- (i) *that the price(s), rate(s) & preference quoted cover all for the work/item (s) & accept that any mistakes regarding the price (s) & calculations will be at the bidder's risk*
 - (ii) *it is the responsibility of the bidder to confirm receipt of their quotation and to keep proof thereof.*
- 3.6. The bidder must accept full responsibility for the proper execution & fulfilment of all obligations conditions devolving on under this agreement, as the Principal (s) liable for the due fulfilment of this contract.
- 3.7. This quotation will be evaluated based on the 80/20 points system, specification, correctness of information and/or functionality criteria. All required documentation must be completed in full and submitted.
- 3.8. Offers must comply strictly with the specification.
- 3.9. Only offers that meet or are greater than the specification will be considered.
- 3.10. Late offers will not be considered.
- 3.11. Expired product/s will not be accepted. All products supplied must be valid for a minimum period of six months.
- 3.12. Used/ second-hand products will not be accepted.
- 3.13. A bidder not registered on the Central Suppliers Database or whose verification has failed will not be considered.
- 3.14. All delivery costs must be included in the quoted price for delivery at the prescribed destination.
- 3.15. Only firm prices will be accepted. Such prices must remain firm for the contract period. Non-firm prices (including rates of exchange variations) will not be considered.
- 3.16. In cases where different delivery points influence the pricing, a separate pricing schedule must be submitted for each delivery point.
- 3.17. In the event of a bidder having multiple quotes, only the cheapest according to specification will be considered.
- 3.18. Verification will be conducted to identify if bidders have multiple companies and are cover-quoting for this bid.
- 3.19. In such instances, the Department reserves the right to immediately disqualify such bidders as cover-quoting is an offence that represents both corruption and acquisition fraud.

4. SPECIAL INSTRUCTIONS AND NOTICES TO BIDDERS REGARDING THE COMPLETION OF THIS QUOTATION.

- 4.1. Unless inconsistent with or expressly indicated otherwise by the context, the singular shall include the plural and vice versa and with words importing the masculine gender shall include the feminine and the neuter.
- 4.2. Under no circumstances whatsoever may the quotation/bid forms be retyped or redrafted. Photocopies of the original bid documentation may be used, but an original signature must appear on such photocopies.
- 4.3. The bidder is advised to check the number of pages and to satisfy himself that none are missing or duplicated.
- 4.4. Quotations submitted must be complete in all respects. However, where it is identified that information in a bidder's response is incomplete in any respect, the said supplier meets all specification requirements and is lowest to quote, the Department reserves the right to request the bidder to complete/submit such information.
- 4.5. Any alteration made by the bidder must be initialled; failure to do so may render the response invalid.
- 4.6. Use of correcting fluid is prohibited and may render the response invalid.
- 4.7. Quotations will be opened in public as soon as practicable after the closing time of quotation.
- 4.8. Where practical, prices are made public at the time of opening quotations.
- 4.9. If it is desired to make more than one offer against any individual item, such offers should be given on a photocopy of the page in question. Clear indication thereof must be stated on the schedules attached.
- 4.10. The Department is under no obligation to pay suppliers in part for work done if the supplier can no longer for fulfil their obligation.

5. SPECIAL INSTRUCTIONS REGARDING HAND DELIVERED QUOTATIONS

- 5.1. Quotation shall be lodged at the address indicated not later than the closing time specified for their receipt, and in accordance with the directives in the quotation documents.
- 5.2. Each quotation shall be addressed in accordance with the directives in the quotation documents and shall be lodged in a separate sealed envelope, with the name and address of the bidder, the quotation number and closing date indicated on the envelope. The envelope shall not contain documents relating to any quotation other than that shown on the envelope. If this provision is not complied with, such quotations/bids may be rejected as being invalid.
- 5.3. All quotations received in sealed envelopes with the relevant quotation numbers on the envelopes are kept unopened in safe custody until the closing time of the quotation/bids. Where, however, a quotation is received open, it shall be sealed. If it is received without a quotation/bid number on the envelope, it shall be opened, the quotation number ascertained, the envelope sealed and the quotation number written on the envelope.
- 5.4. A specific box is provided for the receipt of quotations, and no quotation found in any other box or elsewhere subsequent to the closing date and time of quotation will be considered.
- 5.5. No quotation/bid sent through the post will be considered if it is received after the closing date and time stipulated in the quotation documentation, and proof of posting will not be accepted as proof of delivery.
- 5.6. Quotation documents must not be included in packages containing samples. Such quotations may be rejected as being invalid.

6. SAMPLES

- 6.1. In the case of the quote document stipulating that samples are required, the supplier will be informed in due course when samples should be provided to the institution. (This decreases the time of safety and storage risk that may be incurred by the respective institution). The bidders sample will be retained if such bidder wins the contract.
 - (i) If a company/s who has not won the quote requires their samples, they must advise the institution in writing of such.
 - (ii) If samples are not collected within three months of close of quote the institution reserves the right to dispose of them at their discretion.
- 6.2. **Samples must be made available when requested in writing or if stipulated on the document.**
 - (i) If a Bidder fails to provide a sample of their product on offer for scrutiny against the set specification when requested, their offer will be rejected. All testing will be for the account of the bidder.

7. COMPULSORY SITE INSPECTION / BRIEFING SESSION

7.1. Bidders who fail to attend the compulsory meeting will be disqualified from the evaluation process.

- (i) The institution has determined that a compulsory site meeting take place
- (ii) Date / / Time : Place

Institution Stamp:	Institution Site Inspection / briefing session Official Full Name: Signature: Date:
--------------------	--

8. STATEMENT OF SUPPLIES AND SERVICES

8.1. The contractor shall, when requested to do so, furnish particulars of supplies delivered or services executed. If he/she fails to do so, the Department may, without prejudice to any other rights which it may have, institute inquiries at the expense of the contractor to obtain the required particulars.

9. SUBMISSION AND COMPLETION OF SBD 6.1

9.1. Should a bidder wish to qualify for preference points they must complete a SBD 6.1 document. Failure by a bidder to provide all relevant information required, will result in such a bidder not being considered for preference point's allocation. The preferences applicable on the closing date will be utilized. Any changes after the closing date will not be considered for that particular quote.

10. TAX COMPLIANCE REQUIREMENTS

- 10.1. In the event that the tax compliance status has failed on CSD, **it is the suppliers' responsibility to provide a SARS pin in order for the institution to validate the tax compliance status of the supplier.**
- 10.2. In the event that the institution cannot validate the suppliers' tax clearance on SARS as well as the Central Suppliers Database, **the quote will not be considered and passed over as non-compliant according to National Treasury Instruction Note 4 (a) 2016/17.**

11. TAX INVOICE

11.1. A tax invoice shall be in the currency of the Republic of South Africa and shall contain the following particulars:

- | | |
|--|--|
| (i) the name, address and registration number of the supplier; | (iv) a description and quantity or volume of the goods or services supplied; |
| (ii) the name and address of the recipient; | (v) the official department order number issued to the supplier; |
| (iii) an individual serialized number and the date upon which the tax invoice is issued; | (vi) the value of the supply, the amount of tax charged; |
| | (vii) the words tax invoice in a prominent place. |

12. PATENT RIGHTS

The supplier shall indemnify the **KZN Department of Health** (hereafter known as the purchaser) against all third-party claims of infringement of patent, trademark, or industrial design rights arising from use of the goods or any part thereof by the purchaser.

13. PENALTIES

- 13.1. If at any time during the contract period, the service provider is unable to perform in a timely manner, the service provider must notify the institution in writing/email of the cause of and the duration of the delay. Upon receipt of the notification, the institution should evaluate the circumstances and, if deemed necessary, the institution may extend the service provider's time for performance.
- 13.2. In the event of delayed performance that extends beyond the delivery period, the institution is entitled to purchase commodities of a similar quantity and quality as a substitution for the outstanding commodities, without terminating the contract, as well as return commodities delivered at a later stage at the service provider's expense.
- 13.3. Alternatively, the institution may elect to terminate the contract and procure the necessary commodities in order to complete the contract. In the event that the contract is terminated the institution may claim damages from the service provider in the form of a penalty. The service provider's performance should be captured on the service provider database in order to determine whether or not the service provider should be awarded any contracts in the future.
- 13.4. If the supplier fails to deliver any or all of the goods or to perform the services within the period(s) specified in the contract, the purchaser shall, without prejudice to its other remedies under the contract, deduct from the contract price, as a penalty, a sum calculated on the delivered price of the delayed goods or unperformed services using the current prime interest rate calculated for each day of the delay until actual delivery or performance.

14. TERMINATION FOR DEFAULT

- 14.1. The purchaser, without prejudice to any other remedy for breach of contract, by written notice of default sent to the supplier, may terminate this contract in whole or in part:
- (i) if the supplier fails to deliver any or all of the goods within the period(s) specified in the contract,
 - (ii) if the supplier fails to perform any other obligation(s) under the contract; or
 - (iii) if the supplier, in the judgment of the purchaser, has engaged in corrupt or fraudulent practices in competing for or in executing the contract.
- 14.2. In the event the purchaser terminates the contract in whole or in part, the purchaser may procure, upon such terms and in such manner as it deems appropriate, goods, works or services similar to those undelivered, and the supplier shall be liable to the purchaser for any excess costs for such similar goods, works or services.
- 14.3. Where the purchaser terminates the contract in whole or in part, the purchaser may decide to impose a restriction penalty on the supplier by prohibiting such supplier from doing business with the public sector for a period not exceeding 10 years.

15. FAILURE TO COMPLY WITH ABOVE WILL RESULT IN YOUR QUOTE BEING PASSED OVER.

PREFERENCE POINTS CLAIM FORM IN TERMS OF THE PREFERENTIAL PROCUREMENT REGULATIONS 2017

This preference form must form part of all quotes invited. It contains general information and serves as a claim form for preference points for Broad-Based Black Economic Empowerment (B-BBEE) Status Level of Contribution

NB: BEFORE COMPLETING THIS FORM, BIDDERS MUST STUDY THE GENERAL CONDITIONS, DEFINITIONS AND DIRECTIVES APPLICABLE IN RESPECT OF B-BBEE, AS PRESCRIBED IN THE PREFERENTIAL PROCUREMENT REGULATIONS, 2017.

1. GENERAL CONDITIONS

1.1 The following preference point systems are applicable to all quotes:

- the 80/20 system for requirements with a Rand value of up to R50 000 000 (all applicable taxes included); and

1.2 The value of this quote is estimated to not exceed R50 000 000 (all applicable taxes included) and therefore the 80/20 preference point system shall be applicable.

1.3 Points for this quote shall be awarded for:

- (a) Price; and
- (b) B-BBEE Status Level of Contributor.

1.4 The maximum points for this quote is allocated as follows:

	POINTS
PRICE	80
B-BBEE STATUS LEVEL OF CONTRIBUTOR	20
Total points for Price and B-BBEE must not exceed	100

1.5 Failure on the part of a bidder to submit proof of B-BBEE Status level of contributor together with the quote, will be interpreted to mean that preference points for B-BBEE status level of contribution are not claimed.

1.6 The purchaser reserves the right to require of a bidder, either before a quote is adjudicated or at any time subsequently, to substantiate any claim in regard to preferences, in any manner required by the purchaser.

2. DEFINITIONS

- (a) "B-BBEE" means broad-based black economic empowerment as defined in section 1 of the Broad-Based Black Economic Empowerment Act;
- (b) "B-BBEE status level of contributor" means the B-BBEE status of an entity in terms of a code of good practice on black economic empowerment, issued in terms of section 9(1) of the Broad-Based Black Economic Empowerment Act;
- (c) "bid" means a written offer in a prescribed or stipulated form in response to an invitation by an organ of state for the provision of goods or services, through price quotations, advertised competitive bidding processes or proposals;
- (d) "Broad-Based Black Economic Empowerment Act" means the Broad-Based Black Economic Empowerment Act, 2003 (Act No. 53 of 2003);
- (e) "EME" means an Exempted Micro Enterprise in terms of a code of good practice on black economic empowerment issued in terms of section 9 (1) of the Broad-Based Black Economic Empowerment Act;
- (f) "functionality" means the ability of a tenderer to provide goods or services in accordance with specifications as set out in the tender documents.
- (g) "prices" includes all applicable taxes less all unconditional discounts;
- (h) "proof of B-BBEE status level of contributor" means:
 - 1) B-BBEE Status level certificate issued by an authorized body or person;
 - 2) A sworn affidavit as prescribed by the B-BBEE Codes of Good Practice;
 - 3) Any other requirement prescribed in terms of the B-BBEE Act;
- (i) "QSE" means a qualifying small business enterprise in terms of a code of good practice on black economic empowerment issued in terms of section 9 (1) of the Broad-Based Black Economic Empowerment Act;
- (j) "rand value" means the total estimated value of a contract in Rand, calculated at the time of bid invitation, and includes all applicable taxes;

3. POINTS AWARDED FOR PRICE

3.1 THE 80/20 PREFERENCE POINT SYSTEMS

A maximum of 80 points is allocated for price on the following basis:

$$Ps = 80 \left(1 - \frac{Pt - P \min}{P \min} \right) \text{ Where}$$

- Ps = Points scored for price of bid under consideration
- Pt = Price of bid under consideration
- Pmin = price of lowest acceptable bid

4. POINTS AWARDED FOR B-BBEE STATUS LEVEL OF CONTRIBUTOR

4.1 In terms of Regulation 6 (2) and 7 (2) of the Preferential Procurement Regulations, preference points must be awarded to a bidder for attaining the B-BBEE status level of contribution in accordance with the table below:

B-BBEE Status Level of Contributor	Number of points (80/20 system)
1	20
2	18
3	14
4	12
5	8
6	6
7	4
8	2
Non-compliant contributor	0

5. BID DECLARATION

5.1 Bidders who claim points in respect of B-BBEE Status Level of Contribution must complete the following:

6. B-BBEE STATUS LEVEL OF CONTRIBUTOR CLAIMED IN TERMS OF PARAGRAPHS 1.4 AND 4.1

6.1 B-BBEE Status Level of Contributor: =(maximum of 20 points)

(Points claimed in respect of paragraph 7.1 must be in accordance with the table reflected in paragraph 4.1 and must be substantiated by relevant proof of B-BBEE status level of contributor.

7. SUB-CONTRACTING applicable box)

(Tick

YES		NO	
-----	--	----	--

7.1 Will any portion of the contract be sub-contracted?

7.1.1 If yes, indicate:

- i) What percentage of the contract will be subcontracted.....%
- ii) The name of the sub-contractor.....
- iii) The B-BBEE status level of the sub-contractor.....

8. Whether the sub-contractor is an EME or QSE

(Tick applicable box)

iv) Specify, by ticking the appropriate box, if subcontracting with an enterprise in terms of Preferential Procurement Regulations, 2017:

YES		NO	
-----	--	----	--

Designated Group: An EME or QSE which is at last 51% owned by:	EME	QSE
Black people	√	√
Black people who are youth		
Black people who are women		
Black people with disabilities		
Black people living in rural or underdeveloped areas or townships		
Cooperative owned by black people		
Black people who are military veterans		
OR		
Any EME		

Any QSE		
---------	--	--

9. **DECLARATION WITH REGARD TO COMPANY/FIRM**

9.1 Name of company/firm:.....

9.2 VAT registration number:.....

9.3 Company registration number:.....

9.4 **TYPE OF COMPANY/ FIRM [TICK APPLICABLE BOX]**

- Partnership/Joint Venture / Consortium
- One person business/sole propriety
- Close corporation
- Company
- (Pty) Limited

9.5 **DESCRIBE PRINCIPAL BUSINESS ACTIVITIES**

.....

9.6 **COMPANY CLASSIFICATION [TICK APPLICABLE BOX]**

- Manufacturer
- Supplier
- Professional service provider
- Other service providers, e.g. transporter, etc.

9.7 Total number of years the company/firm has been in business:.....

9.8 I/we, the undersigned, who is / are duly authorised to do so on behalf of the company/firm, certify that the points claimed, based on the B-BBE status level of contributor indicated in paragraphs 1.4 and 6.1 of the foregoing certificate, qualifies the company/ firm for the preference(s) shown and I / we acknowledge that:

- i) The information furnished is true and correct;
- ii) The preference points claimed are in accordance with the General Conditions as indicated in paragraph 1 of this form;
- iii) In the event of a contract being awarded as a result of points claimed as shown in paragraphs 1.4 and 6.1, the contractor may be required to furnish documentary proof to the satisfaction of the purchaser that the claims are correct;
- iv) If the B-BBEE status level of contributor has been claimed or obtained on a fraudulent basis or any of the conditions of contract have not been fulfilled, the purchaser may, in addition to any other remedy it may have –
 - (a) disqualify the person from the bidding process;
 - (b) recover costs, losses or damages it has incurred or suffered as a result of that person's conduct;
 - (c) cancel the contract and claim any damages which it has suffered as a result of having to make less favourable arrangements due to such cancellation;
 - (d) recommend that the bidder or contractor, its shareholders and directors, or only the shareholders and directors who acted on a fraudulent basis, be restricted by the National Treasury from obtaining business from any organ of state for a period not exceeding 10 years, after the *audi alteram partem* (hear the other side) rule has been applied; and
 - (e) forward the matter for criminal prosecution.

<p>WITNESSES</p> <p>1.</p> <p>2.</p>

<p>.....</p> <p>SIGNATURE(S) OF BIDDERS(S)</p> <p>DATE:</p> <p>ADDRESS.....</p> <p>.....</p> <p>.....</p>
--



TECHNICAL SPECIFICATIONS

Indoor mechanically ventilated sputum collection booth

APRIL 16, 2019

CSIR

CSIR, Smart Places Cluster, P Bag 395, Pretoria, South Africa

1 General

1.1.1 Where reference is made to Contractor, it shall be read to mean the successful bidder appointed to execute the contract.

1.2 Materials and workmanship

1.2.1 All apparatus, components parts, fittings and materials supplied and/or installed whether especially specified herein or not shall conform in respect of quality, manufacture, tests and performance with the requirements of the appropriate current South African (SABS) or British Standard Specifications (BS).

1.2.2 All materials and workmanship which may, in the opinion of the CSIR, be inferior to that specified for the work shall be condemned. All condemned material and workmanship must be replaced or rectified as the case may be, to the satisfaction of the CSIR.

2 Performance specifications

2.1 Supply Air flow rate

2.1.1 Supply air flow rate shall be at least 2100 m³/h measured as specified herein

2.2 Air exchange rate

2.2.1 The sputum collection booth ventilation rate shall be at least 800 Air Changes per Hour (ACH).

2.3 Booth internal air pressure requirements

2.3.1 The booth shall maintain a negative air pressure with respect to adjacent spaces during operation. No outward airflow is permitted during closed door operation.

2.4 Aerosol filtration requirements

2.4.1 The HEPA filter shall achieve a filtration efficiency of not less than 99.95% when tested as per section 6.4.1 – 6.4.3.

2.5 Noise levels

2.5.1 Noise levels shall not exceed 40 dB 1m away from the booth as per SANS 10103:2008.

2.5.2 Acoustical noise levels shall be compliant with §2.5.1 when tested in accordance with ISO 3743-1 and ISO 3743-2

3 Design specifications

3.1 Booth dimensions

3.1.1 Booth inner dimensions (mm) shall be 1600Lx734Wx1900H.

3.1.2 Booth outer dimensions (mm) shall be 2000Lx740Wx2000H.

3.2 Configuration of aerosol filtration system and fan

3.2.1 Aerosol filtration system (pre and HEPA filters) and fan shall be configured as shown in the schematic diagram of Figure 2.

3.3 Internal booth surfaces

3.3.1 The internal surfaces of the booth shall be impervious (no gaps or voids), able to withstand regular and vigorous cleaning, washable and easily disinfected.

3.4 Filtration housing

3.4.1 Filtration housing for the Pre and HEPA filter shall be N G™ filter duct housings.

3.5 Plenum

3.5.1 The plenum shall be detachable from the booth See Figure 3.

3.5.2 4 lockable or retractable wheels shall be provided to the plenum for mobility.

3.6 Inlet air filtration

3.6.1 A G4 air filter matt shall be situated over the fresh-air intake screen.

3.7 Location of supply air grill

3.7.1 The perforated supply air grille shall be located on the ceiling of the booth and shall have an open area of not less than 50% and a hole shape aspect ratio of 1:1.

3.7.2 The grille shall be configured to ensure an even supply airflow distribution throughout the sputum collection booth.

3.7.3 The thickness of the grille shall be at least 0.8 mm.

3.8 High Efficiency Particulate Air (HEPA) filter

3.8.1 An EN 1822 H13 Grade HEPA filter shall be installed as per arrangement shown in the schematic diagram Figure 2.

3.9 Fan

3.9.1 Fan shall be an automatic step less variable speed fan.

3.10 Pre Filter

3.10.1 An F9 filter shall be installed as per arrangement shown in the schematic diagram Figure 2.

3.11 Booth lighting

3.11.1 LED lighting strips shall be installed along the inside gloss white walls above head height.

3.12 sputum cup holder

3.12.1 The sputum cup holder shall be installed along the inside wall of the booth below the window as shown in Figure 3.

3.12.2 The material of the cup holder shall be Perspex or Stainless steel.

3.13 Seat

3.13.1 The seat shall be foldable and able to withstand a dynamic load of 150 kg.

3.14 Window

3.14.1 A window shall be installed as per schematic diagram of Figure 2.

3.15 Pressure gauges

3.15.1 Pressure gauges with a maximum range of 500 Pa shall be installed across the HEPA filter and the pre filter.

3.16 Automatic door lock system

3.16.1 Automatic door lock system shall be installed.

3.16.2 The control logic for the door shall be as per Figure 1.

4 DRAWINGS

4.1.1 Figures 2&3 are presented for general arrangement purposes.

4.1.2 The contractor shall prepare shop drawings which shall show in detail the construction of all the parts, method of assembly where applicable, materials and connections, sealants, fastenings and all other necessary details.

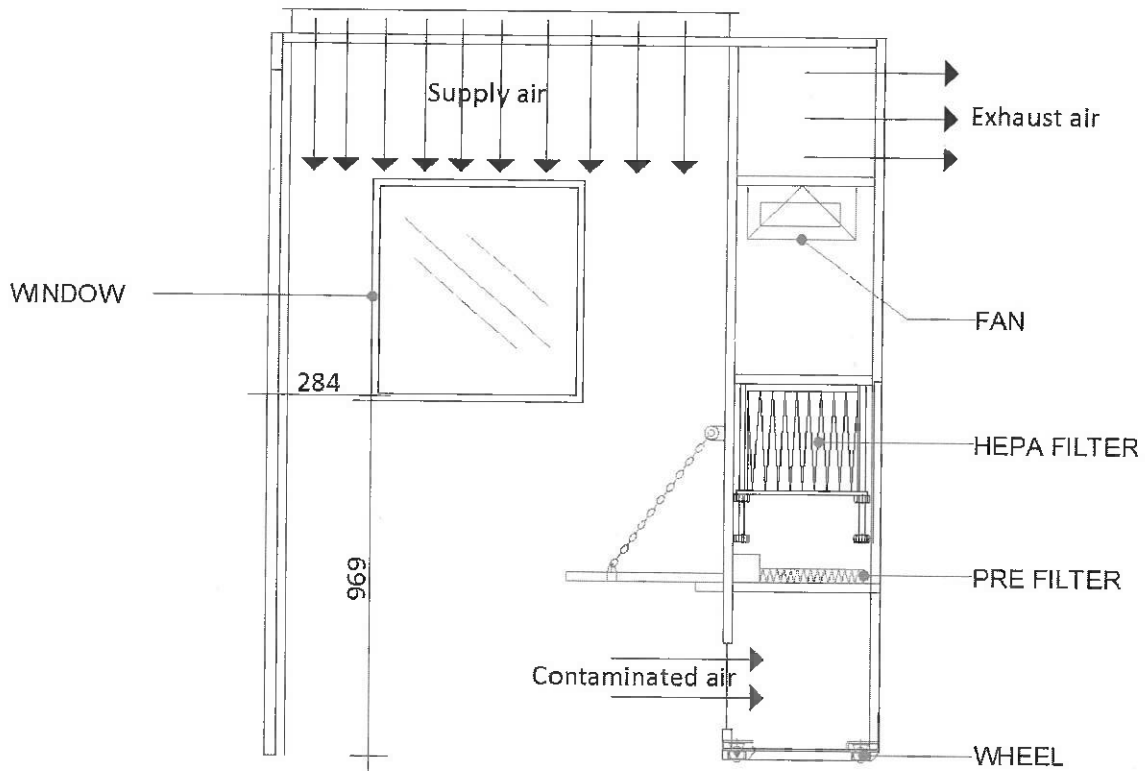

Figure 2. General arrangement of booth

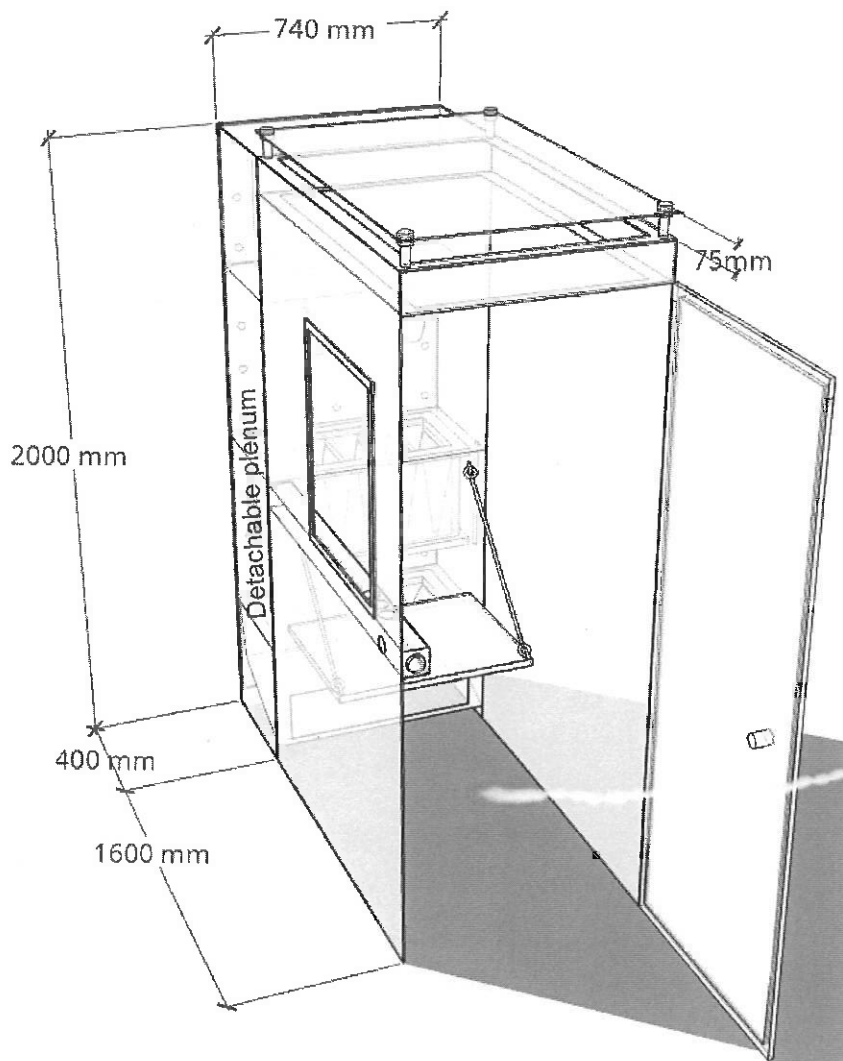

Figure 3. General arrangement of sputum booth

5 Installation

5.1 Indoor location of booth

- 5.1.1 The sputum booth shall not be located close to open windows and doors.
- 5.1.2 The sputum booth shall not align with commonly viewed items such as notice boards, monitors, televisions etc.
- 5.1.3 Total of 5 sputum booths shall be installed in healthcare facilities located in the following areas:
 - i. Durban
 - ii. Cape Town
 - iii. Rustenburg
 - iv. Polokwane
 - v. Ekurhuleni
- 5.1.4 The CEOs or infection control managers of the facilities of sections 5.1.3 shall allocate the exact installation location within the facility.
- 5.1.5 The contractor shall allow in his tender price for the transportation costs of booths to installation sites.

6 Commissioning

6.1 Testing responsibility

- 6.1.1 The contractor shall allow in his tender price for the services of appropriately certified commissioning technicians or engineers.

6.2 Airflow direction tests

- 6.2.1 Airflow direction tests to confirm negative booth pressure shall be conducted as per ISO 14644:3 section B8.

6.3 Booth ventilation rate

- 6.3.1 Booth ventilation rate shall be tested as per ISO 14644:3 for non-unidirectional airflow system. The test shall be conducted at the exhaust air terminal.

6.4 HEPA Filter integral efficiency test

- 6.4.1 HEPA Filter integral efficiency test shall be as per ISO 14644:3.

- 6.4.2 Challenge aerosol particle size shall be as per ISO 14644:3 section B.6.2.2
- 6.4.3 Challenge aerosol concentration in the booth shall be as per ISO 14644:3 section B.6.2.3.

7 MAINTENANCE AND PERFORMANCE MONITORING

- 7.1.1 The contractor shall maintain good working order of the sputum collection booth for 2 years after installation.
- 7.1.2 Fully comprehensive two year maintenance and monitoring plan including all costs shall be provided by the contractor.
- 7.1.3 The maintenance plan shall include maintenance activities and performance monitoring.

8 GUARANTEE PERIODS

- 8.1.1 The contractor shall guarantee that spare parts will be available for the expected lifetime of the sputum collection booth and for a period of at least ten years from procurement date.
- 8.1.2 The guarantee must cover all items against manufacturing defects, installation, commissioning, materials and workmanship. Should manufacturing defects be detected within a 30-day period, the supplier shall replace the equipment with a new one.
- 8.1.3 Contractors are obliged to refund, repair or replace the failed, unsafe and defective goods.

9 Documentation

- 9.1.1 The following reports and records shall be provided upon handover:

- 1) Manual including:
 - a) Operating instructions
 - b) Maintenance schedule and instructions
 - c) Shop drawings
 - d) All tests reports
 - e) Material data sheets

- f) Equipment data sheets
- g) Decommissioning and disposal plan

10 TRAINING

10.1.1 Training of onsite maintenance personnel and sister in charge by the contractor in the operation, dismantling and cleaning of the sputum collection booth shall be included in the offer.

11 COSTING

The following 3 quotations shall be provided:

- i. For 3 Booths; costs shall include:
 - Supply cost per booth
 - Delivery and installation cost per booth per any of the 3 areas listed in section 5.1.3.
 - Commissioning and validation cost per three areas as selected above.
 - Maintenance inspections/interventions costs per three areas as selected above per year
- ii. For 5 Booths; costs shall include:
 - Supply cost per booth
 - Delivery and installation cost per booth per area of 5 areas listed in section 5.1.3.
 - Commissioning and validation cost per booth per area of 5 areas listed in section 5.1.3.
 - Maintenance inspections/interventions costs per booth per area of 5 areas listed in section 5.1.3 per year.
- iii. For 100 Booth; costs shall include:
 - Supply cost per booth
 - Delivery and installation cost per booth per province
 - Commissioning and validation per booth per province.
 - Maintenance inspections/interventions per booth per province per year

NB: Minimum order quantity shall be provided for the 100 booths quotation.