



# INKANYEZI YASEMPHUMULO

P/ Box X 9212, Maphumulo 4470; Telephone 032-481 4000; Fax: 032-4812009  
Email: lungile.ntenga@kznhealth.gov.za;  
Webpage:www.kznhealth.gov.za/umphumulohospital.htm

UMPHUMULO HOSPITAL



## INSIDE THIS ISSUE:

|                                 |   |
|---------------------------------|---|
| CEO'S Corner                    | 1 |
| Editor's Corner                 | 2 |
| Teenage Pregnancy Awareness Day | 3 |
| Ho to handle criticism          | 4 |
| Vitamin A campaign              | 4 |
| Healthy Lifestyle Awareness Day | 5 |
| Sports/ Ezemidlalo              | 6 |
| New enrollments                 | 7 |

VOLUME 1, ISSUE 1

JANUARY TO APRIL 2009



MRS T.D. CHILIZA - CEO

I would like to take the opportunity of welcoming the few personnel that joined the institution in 2009. I hope you find the peaceful surroundings habitable, welcoming and the work challenging. I hope your stay in Umphumulo will be a memorable one.

On the financial side we are on the last quarter. The road that has been traveled in the past year has to be evaluated. It is lucky that the institution was able to sustain the existing services and not be in a position to cut down on any. The institution has had to do without a lot of items though. Cash flow meetings have become more interesting with some of the personnel defending their requests to a "bitter end". MTEC meetings have been enlightening with more personnel being involved in financial issues which promoted behavioural change.

## CEO'S CORNER

Community complaints regarding shortages of medication have been addressed by clinic visits and an Imbizo at one of the clinics where concerns were attended to..

As promised 2009 is not going to be any better. As stated in the previous newsletter plans to offload OPD patients to PHC services have to be put in place. In doing this a "health post" is to be opened at Maphumulo town. This is not considered as an expansion of the service but rather an enhancement as there has always been a visiting mobile clinic to this point. This is in perfect alignment with the Departmental plans as the health post being established is about a hundred metres from an approved clinic site. This will encourage the community to start utilising the PHC service even before the new clinic is built. Existing HR will be utilised. The institution is very excited about this move as it will address many issues like lengthy waiting times and the pharmacy expenditure.

To the committed staff at this institution, Management salutes your perseverance over the past year as it does look like our goal has been achieved. All our efforts have paid off. Savings are in the vicinity of 40-50% of the previous year's over expenditure.

Remember "The superior man is modest in his speech, but exceeds in his actions" (Confucius). Talk little do more. Let us strive to enjoy 2009.



## EDITORS CORNER

**T**o the hospital management, board members, all the departments within the institution and the community at large, receive my humble greetings. Let me take this opportunity to throw a word of gratitude to my creator and Lord Jesus, who has always been on my side all the way up to here. My service is to represent the institution in all internal and external stakeholders concerns. It is my responsibility to assist you in accordance with Batho Pele principles in order for you to gain faith and trust in the services rendered by this institution. I am intending to work hard in order to achieve the vision and mission of the institution even though we are still facing financial constraints.

My duty is to maintain peaceful communication within the institution, informing you about relevant information pertaining to the institution.

Watch this space and learn more about things that are going to take place within the institution as I am going to keep you informed.

I hope you will find my first issue of Inkanyezi yaseMphumulo interesting.



Ms Lungile Ntenga - Public Relations Officer



## FRIENDLY TIPS ON HOW TO SAVE ELECTRICITY

In the past year, we faced horrible power failures and that caused a reduction in the production and many companies were negatively affected. After that horrible experience Eskom and lots of other companies agreed to engage in a 10% less energy usage.

### It's Winter time and what does this mean to you!

- Switch off lights in the rooms that are not in use and when you only watching the television you don't have to have the lights on.
- The geyser must be switched off at night and during the day, switch it on at about two hours in the morning before bathing and at night two hours before bathing.
- Switch off the air conditioner and the computer when no one is in the office.
- Switch off radios and televisions, do not leave these in a standby mode.

These are just few points that we can do to try to minimize the usage of electricity at home and also in the workplace. This is common sense good people, each and everyone must be cautious at all times by using the electricity wisely.

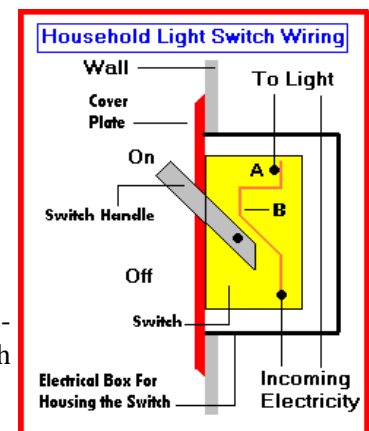

[www.1728.com](http://www.1728.com)

PAGE 2

# PREGNANCY AWARENESS DAY

*“Give yourself permission, when faced with a serious situation, to give voice to your feelings, smile, hold your head up high and put your right foot forward. Do not leave for tomorrow what can be done today.”  
(unknown)*

**N**gomhlaka 12 kuNhlolanja elinye lamaklinikhi ethu uMbhekaphansi Clinic ubambisene no MCDI okuyinhlango ezimele bebehlele umcimbi wokugubha omayelana nokukhulelwa okunempilo kukamama womntwana, yona lenyanga bekuyisonto elibizwa ngokuthi i-Pregnancy Week ekhalendeni lethu Lezempilo.

Lomcimbi ubuhanjelwe izikhulu eziphezulu kakhulu ezivela e-ILembe Health District Office, Umphumulo Hospital, MCDI, Abefundisi kanye nabaholi bendawo uqobo. Umphakathi wawuphumelele ngobuningi bawo wawulingiselwa ku 360. Inhlalo yomcimbi wonke kwakuwukufundisa umphakathi ngokunakekelwa komntwana osakhulelwe. Lapho okwabonakala kuwu

Izikhulumani zethu ezazihlukahlukene zashaya ngegalelo eliphezulu kakhulu, ziqwashisha ayi kuphela omama kodwa futhi neqhaza likababa njengengxenywe yomntwana ngokuthi: umama uyaludinga uxhaso nothando kanye nokunakekelwa ubaba wekhaya ngenkathi esazithwele, ukuze isimo sempilo yamama ibe lula.

Okunye okwathinteka okwakubalulekile ukuthi umama ngenkathi esazithwele uma ezwa kungahambi kahle ngenkathi esazithele –uma ezwa izinhlungu ezingajwayelekile angahlali ekhaya akaphuthume emtholampilo ukuze ayothola usizo ngokuphazima kweso.

Zaphinde zagxila kakhulu ngasohlelweni lwe PMTCT (uhlelo lokuvikela umntwana angasuleleki ngegciwane lesandulela ngculazi), ukubaluleka kokuxukuza kukamama okhulelwe, nokudla okunempilo kumuntu okhulewe.

Kwakukhona-ke nezihlobonhlobo zezinandisi zomculo owuhleliwe, kanye namanhlaya okwakwenza lomcimbi ube mnandi kakhulu, Sithanda ukubonga kakhulu umphakathi wethu wakwaMaphumulo namaphethelo ngokuphumelela ngobuningi bawo kanye nokuzihlonipha nangokusebenza ngokubambisana.



Dept. Banner



Mrs T.D Chiliza– CEO



Ms Bongi Mofokeng  
( DOH Provincial  
Office)



# HEALTHY LIFESTYLE AWARENESS DAY

**O**n the 10th of February 2009 marked an auspicious day for Umphumulo Rehabilitation team; it marked the start of the first annual Healthy lifestyle awareness day.

The theme of the day was *Vuka Uzibambe Mphumulo*, staff members were kitted out in the latest sporting gear as the theme for the day was movement. The day started with staff members getting their vitals done-Bp, Cholesterol, BMI, Glucose, height and weight were done by the occupational health sister, Ms CD Khuzwayo and Sister TP Nxumalo. A healthy lifestyle event marked the highlight of the day. The various departments within the hospital gave talks relating to the theme of the day.

Our CEO Mrs. TD Chiliza honoured the event with a prayer. Our resident doctor Dr Parikh gave an informative talk on lifestyle illness-the signs, symptoms and treatments. Mr. SB Blose from our district office spoke about Victim empowerment. The bubbly Ms Ndingi highlighted the importance of healthy teeth. Mr. N.B Manqele from TB clinic spoke about TB treatment and precautions. Ms F Mzoneli educated staff on the importance of medication compliance. Sex and your sexual lifestyle was the focus of Mr. L Khumalo's talk. Our new community service, Ms S Lakshminarayana and Ms D Mzimela from the rehab team gave a dynamic show and tell on stress management and exercise.

Questions were asked at the end of each speakers talk to evaluate the understanding of staff. Prizes were given to persons who answered correctly.

The event ended with the handing off tooth brushes, Colgate, refreshments, fruit and different pamphlets.

Staff members left the event psyched up to change their lifestyles as the message was spread.

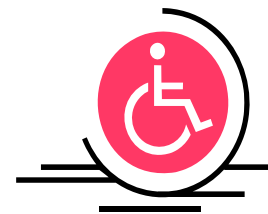

## HOW TO HANDLE CRITICISM

- **TRAIN YOUR EGO**

Expose yourself to as much constructive criticism as you can. Desensitize yourself. See your self more objectively.

- **KNOW WHAT HONESTY REALLY IS - THE POLICY**

Be open to constructive criticism and Encourage people to give you honest feedback.  
don't do it if you only want praise or validation

- **FOCUS ON WHAT NEEDS TO CHANGE**

Ask the person for specifics such as "what could I have most improved?" Or "what did you like least?"

- **DON'T ARGUE OR MAKE EXCUSES**

It shows a lack of maturity to argue with or attack your critic, also listen to what is being said rather than justifying yourself

- **ASK FOR CRITICISM IN WRITING**

Listening to criticism is extremely difficult, it may help to ask the person to write down their comments so you can go over it again later. This will give you a chance to look at it more objectively and then you can really give it some thought

- **I UNDERSTAND, BUT DISAGREE**

Calmly stating these four words shows the person that you are open to suggestions even if you don't agree

- **THANKS, I'LL THINK ABOUT IT**

These five words will end the conversation calmly and give you time to process any particularly crushing information



## UMPHULULO PHC VITAMIN A CAMPAIGN

Our PHC teams were involved in a vitamin A campaign in the Maphumulo sub-district. A Launch was held on the 23 March 2009, in Untunjambili hospital. The main purpose of the event was to provide Vitamin A as immunization to the children from the age of 0-5 and 6-12 years of age, the campaign took a week where the Primary Health Care team was visiting their regular points as well as different schools that are under Maphumulo district, to ensure that all children are not left out. Participation of the hospital staff was encouraged as the campaign was not only for the PHC. Good team work was visible. We would like to pass the vote of thanks to all our staff.



# SPORTS AND RECREATION

## SIYOHLALE SIBABHAXABULA!!

Umphumulo Netball and Soccer team took part in friendly games which was held in Eshowe. The games consisted of different teams from, Sundumbili CHC and Eshowe hospital The overall winners of all the games were Umphumulo hospital teams both netball and soccer .

Netball Team Score: Umphumulo 11 V.S Eshowe 7  
Umphumulo 13 V.S Sundumbili CHC 10

Soccer Team Score: Umphumulo 5 VS Eshowe 0

Umphumulo 2 V.S Sundumbili CHC 0

Regardless of the challenges we have faced including the weather condition that was also a challenge to us, but we would like to congratulate both our netball and soccer team for their hard work and commitment and together with their good team spirit! PHAMBILI BAFANA!



NGENHLA: IYO INKUNDLA LE ESABABHAXELA KHONA.

*Possession of the ball is the key to winning in football, netball, basketball, and the game of life*



## WELCOMING

### JANUARY 2009

1. Ms S. Lakshminarayana - O.T Community service
2. Ms L. N Ntenga - PRO
3. Ms S.D Mzimela - Physio Community service
4. Ms L. Nundulal - Snr Radiography
5. Ms N.H. Nkonyane - Prof Nurse
6. Ms P.T . Nzuzza - Prof Nurse

### FEBRUARY 2009

- 1 Ms N.P Ngcobo Prof Nurse
- 2 Ms N.V Dube Prof Nurse
- 3 Ms T.P Luhtuli—Nursing Assistant
- 4 Mr W. Mandla

## DECEASED

### MARCH 2009

Ms N. Mthiyane - Lab Assistant  
Mrs V.P Dumakude - Prof Nurse: Eye Clinic

**You are to be holy to me because, I the LORD, am holy, and I have set you apart from the nations to be my own.  
Lev: 20:26**

**May their souls rest in peace!**



For your inputs, comments, suggestions and enquiries -the suggestion box is always provided below ! Or kindly contact the Public Relations Officer on:

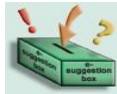

032 - 481 4100 Ext 4198  
Fax: 032- 481 2009  
Email address  
lungile.ntenga@kznhealth.gov.za

**We are also on the web**

<http://www.kznhealth.gov.za/umphumulohospital.htm>

**COMPILED BY MS: LUNGILE  
NTENGA (PRO)**

